

# Wireless World

## Licence for what?

**Editor-in-chief:**

W. T. COCKING, F.I.E.E.

**Editor:**

H. W. BARNARD

**Technical Editor:**

T. E. IVALL, M.I.E.R.E.

**Deputy Editor:**

B. S. CRANK

**Assistant Editors:**

J. GREENBANK, B.A.

G. B. SHORTER, B.Sc.

**Drawing Office:**

L. DARRAH

**Production:**

D. R. BRAY

**Advertisements:**

G. BENTON ROWELL (*Manager*)

G. J. STICHBURY

A. PETERS (*Classified Advertisements*)

Telephone: 01-928 3333 Ext. 533 & 638.

Since the days of Benjamin Disraeli when he gave the British Post Office the monopoly of the electric telegraph, the Postmaster General (now the Minister of Posts and Telecommunications) has progressively controlled the use of wireless telegraphy and, under the current Wireless Telegraphy Act, he now controls the emission and reception "of electromagnetic energy of a frequency not exceeding three million megacycles a second" (whether or not they are used for communication).

The Minister does, of course, grant people a licence to use a small slice of his monopoly — whether it be for broadcasting, civil communications, navigational aids, or amateur operation — for a fee. It is general knowledge that it is an indictable offence to transmit without having been granted a licence — albeit some motorists radiate a pretty fat signal from their cars!

So far we have mentioned only the transmitting aspect although, of course, most transmitting licences permit the reception of signals; but what of those who wish to operate only receiving equipment?

We ask this question because the situation has become confused, at least in the minds of some, since the withdrawal of the sound broadcast receiving licence.

To see the present situation in true perspective one has to look back to the early days of broadcasting, and indeed before the advent of the B.B.C., which celebrates its 50th birthday in 1972. Even when the only broadcasts — at least in Europe — were of time signals and weather reports from Nauen or Eiffel Tower it was illegal to operate an 'experimental station' without a Post Office licence. Then came the broadcasting boom and the steady growth in the number of broadcast receiving licences from a few hundred to ten million when in 1946 a separate television licence was introduced. Up to that time the licence fee of ten shillings was indeed a fee for the right to operate a broadcast receiver. Then larger and larger allocations were made from the income from licence fees to finance the B.B.C. Now, except for a 'collecting fee' claimed by the Post Office, and expenses incurred in the investigation of interference, the whole of the income from the 16 million television licences goes to the B.B.C. It is, therefore, no longer a *licence* fee but a *programme* charge.

Readers may well ask why we should now be getting steamed up about something which has been going on for a very long time. Quite unwittingly we have, apparently, been inciting readers to break the law. Little did we think when we published the recent articles on the reception of weather maps from satellites that a special receiving licence would be required by those who made and operated the equipment described.

We are told by the Ministry of Posts and Telecommunications, although we have so far not received this in writing, that it is illegal to receive transmissions from a satellite. Apparently, a television licence — the only receiving licence now generally available to the public — permits, as did the sound licence, reception of 'authorized broadcasting stations . . . and licensed amateur stations' and a satellite is *not*, we are told, a broadcasting station!

A similar situation exists, of course, regarding the reception of aircraft v.h.f. transmissions and those in the marine radio band. For although receivers covering these bands are available to the public it is illegal to use them. The Ministry's snoopers would have a field day among the plane spotters at any airport!

As a journal, we have always maintained the need for law and order in the transmission and reception of 'electromagnetic waves' although from time to time we have been critical of the administration. We would venture, therefore, to suggest that the time has come for the Radio Regulatory Branch of the Ministry of Posts and Telecommunications to overhaul the licensing machinery which it inherited from the Post Office. Could we not have one receiving licence covering all types of transmission?

# Four-channel Stereo

## An introduction to matrixing

by Geoffrey Shorter

This article is loosely called four-channel stereo so that it can cover a number of techniques, depending on how the words 'channel' and 'stereo' are interpreted. In a strict sense, four-channel stereo could be held to cover the technique of conveying four ideally independent ('discrete') channels of information, as exemplified by the numerous four-channel tape recorders, and more recently tape cartridge players. In this case, a four-channel master tape is the starting point, and the four tracks are made for reproduction from loudspeakers situated to the left front, right front, left back and right back of the listener. A convenient short-hand notation for this is 4-4-4, the first digit representing the number of tracks on the master tape, the second digit representing the number of independent transmission channels, and the third digit representing the number of reproduced channels. There are clearly problems of how to transmit four independent channels in broadcasting and with discs. Solutions\* to these problems have been, and no doubt will continue to be, proposed but it will be some time before all the problems are resolved and techniques standardized. (One commonly quoted estimate is five years.)

There is a way of avoiding the problem of how to transmit four independent channels, and that is by 'matrixing'. In this technique four channels are combined into two and then re-formed to give four channels. This is achieved without recourse to multiplexing with its increased bandwidth requirement, but suffers from crosstalk between channels — not necessarily a disadvantage as far as localization is concerned, as will be shown later. Using the same kind of shorthand this is often called a 4-2-4 technique, although the last digit shouldn't be taken to imply four independent channels. Main contenders in these 'coding' techniques are CBS, Dyna, Electro-Voice, Nippon-Columbia, and Sansui. Both 4-2-4 and 4-4-4 methods are commonly called quadrasonic systems.

Also, various methods have been proposed to produce sound through four

loudspeakers from an ordinary two-channel disc (see for instance references 1 and 2). In shorthand form this could be labelled a 2-2-4 technique. Here the signals can be distributed to the four speakers in a simple way, with difference signals ( $L-R$ ) in the two rear speakers, with 180 or 90° phase difference between them or by, in addition, introducing a specified amount of crosstalk between the rear two speakers and sometimes between the front two speakers. The reasoning is that while reverberant sound is recorded along with direct sound it is largely masked by the direct sound. Because of the incoherent nature of reverberant sound, there is no cancellation in a difference signal, which means it will not be masked to the same degree. Amounts of front and rear crosstalk are not necessarily equal. Also in three of these systems, the crosstalk can be switched in or out. Systems that will give a four-speaker output from two-channel media, and on which information is available, are

maker	crosstalk <sup>1</sup>	
	front	rear
Ordinary speaker matrix	none	0dB (180°)
Dyna Mk II	none	6dB
Electro-Voice <sup>2</sup>	14-15dB	3dB
JVC	none	0dB <sup>3</sup>
	none	6dB
	8dB	6dB
KAI	21dB	0dB (180°)
Pioneer	none	0dB (90°)
	none	6dB
Sansui	3dB	3dB <sup>4</sup>
Sanyo	none	1.4dB (180°)
	none	1.4B <sup>3</sup>
Trio/Kenwood	none	3dB
Zenith	none	2dB

1. left to right or right to left only
2. this system recently changed
3. phase relation is frequency dependent (see ref. 2)
4. phase modulated and frequency dependent

Other makers are involved, like Gately, Grundig, Onkyo, Toshiba, National, Nippon-Columbia, Skandia, but either system details are not available, the system is being changed, or it is similar to one of the above. Makers using the simple ordinary speaker matrix are not included as there is no difference between them subjectively (Pye, Körting, etc). Coded discs are available for some of the systems mentioned — Electro-Voice (for Zenith equipment also), Dyna, Sansui, Nippon-Columbia — but it's not clear at

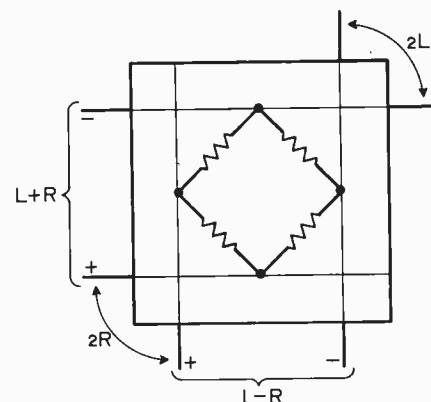

Fig. 1. A matrix is generally an array of intersections between inputs and outputs, with connecting elements at the intersections. This simple example is the basic matrix used in stereo decoders, with resistors as the elements.

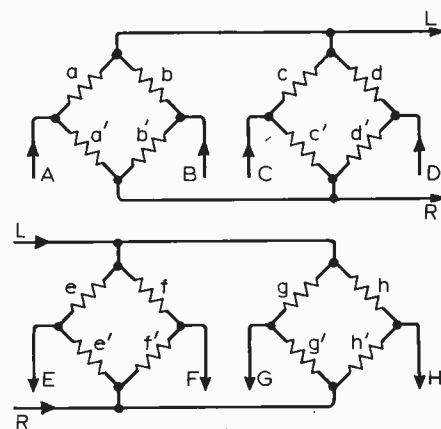

Fig. 2. Generalized amplitude matrix for putting four input channels of information into two output channels. Each input is put onto the two output lines differently.

this time whether discs coded to any other systems are being made. Figures in the table refer only to the 2-2-4 case and not to the coded, 4-2-4 case. (There would be front 'crosstalk' in all cases mentioned with coded discs.) These 2-2-4 methods are given a variety of names, like quadralized and synthesized sound systems, and although some people are calling them

\*One solution to the disc problem has been proposed by the Victor Company of Japan (JVC) and equipment for this is being made by Matsushita (National) as well as JVC. Also RCA plan to produce discs sometime during 1972. The system is described briefly in reference 1.

four-channel stereo, they are certainly not quadrasonic, and a better name might be four-speaker stereo.

Of the three kinds of system mentioned so far, the 4-2-4 is looked on as a stop gap but it would not be surprising if a matrix system came to stay. But if one system is to be agreed as standard, a rigorous evaluation programme is needed, — because there is no agreement on which is subjectively best — like the technical evaluation currently being carried out by a recently formed sub-committee of the Electronic Industries Association (U.S.A.), and the subjective evaluation planned shortly by John Mosely of Command Studios, London. It may be some time before a decision is reached, which leaves record companies with the problem of choosing a system. This problem need not trouble the consumer-equipment buyer provided a universal (switchable) decoder were designed and its production licensed. One company (Electro-Voice) say they have an integrated circuit chip for decoding all existing matrixed material *without* switching. It does not seem possible to design a decoder that will cater for all methods optimally without switching, so — in the absence of detailed information — it must be assumed this will not give optimum results on all systems.

**What is matrixing?**

First let's clarify what 'matrix' means. In the mathematical sense it is a rectangular array of numbers and in the electrical sense it is usually a rectangular array of intersections between inputs and outputs, with elements between some, usually functioning as a coder or decoder. An example is a binary-to-decimal decoder with simple diode gates as the elements connecting appropriate intersections. Perhaps more familiar is the stereo broadcast matrix decoder in which there are resistors as elements between the intersections (Fig. 1).

In the present context a coder would have four input lines and two output lines. Clearly the four input signals must be put onto the two output lines in different ways — otherwise they would become inseparable. The elements at the intersections could be networks with different attenuations, or they could introduce various phase differences.

If we generalize too much things can get very tiresome algebraically. Take the network shown in Fig.2, where the four inputs are A, B, C and D, put onto the outputs L and R with gains represented by a, a', b, b' etc. In decoding this with a similar array, we have four outputs E, F, G, H, each derived by taking the L and R composite signals and treating them with different gains. A generalized output from E would be  $E = A(ea + e'a') + B(eb + e'b') + C(ec + e'c') + D(ed + e'd')$ . By writing out the other three equations for F, G and H it becomes clear that the penalty in combining four signals in this way is that signals come from all four

outputs when only one input is present. (In practice making some coefficients negative gives cancellation of some terms so that signals come from only three outputs for any *one* input.) These equations relate only to amplitude mixing but matrixing can be achieved using phase differences between channels or a combination of both. The algebra of the most general cases can get complicated so it pays to simplify before going on.

One constraint that simplifies choosing coefficients is that power delivered in the two-channel mode from any input should be constant (or from a signal panned\* around 360°). As well, constancy in output is desirable when panning around a four-speaker array. Another is that crosstalk between desired and unwanted outputs is minimized if the decode or playback coefficients are the same as the coding coefficients. With these kinds of constraint we might have the following equations (as typical of a simple amplitude matrix)

$$L = aL_F + bR_F + aL_B - bR_B$$

$$R = bL_F + aR_F - bL_B + aR_B$$

where L and R represent the two transmission channels, L<sub>F</sub>, for instance, represents the left front input channel and where a<sup>2</sup> + b<sup>2</sup> = 1, representing the constant power constraint. For decoding, using the converse matrix, the equations would be

$$L'_F = aL + bR$$

$$R'_F = bL + aR$$

$$L'_B = aL - bR$$

$$R'_B = -bL + aR$$

where L'<sub>F</sub>, for instance, represents the signal in the output corresponding to input L<sub>F</sub>. Substituting the equations for the coded signals in the above gives

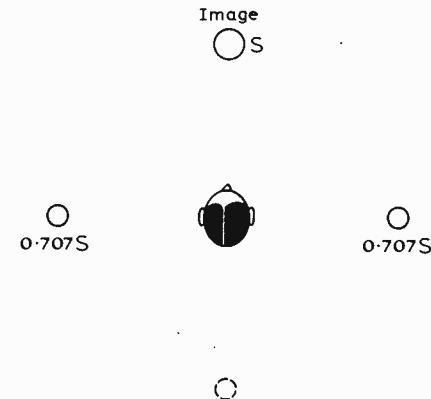

Fig. 3. Relatively high amounts of crosstalk between adjacent speakers can be tolerated when localizing with more than two speakers. (Opinions seem to vary about whether this holds for the listener facing between two speakers — see ref. 5.)

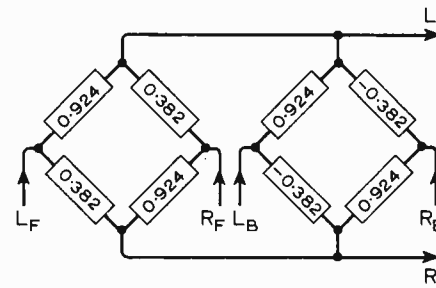

Fig. 4. A simple coding matrix derived in the text which, with a similar decoding matrix, gives equal outputs from speakers either side of the speaker with the wanted output.

\*A panoramic potentiometer, which distributes a signal between two adjacent channels of the four so that total power is constant. uses a sine-cosine law.

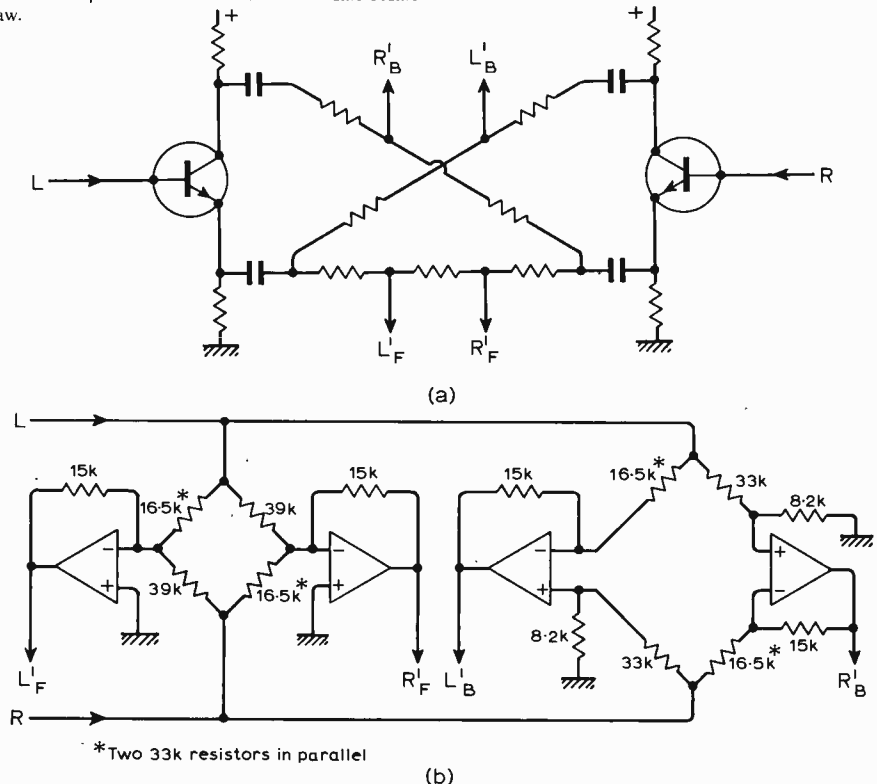
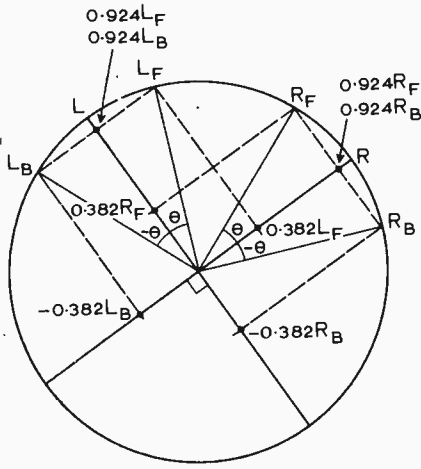

Fig. 5. Two practical realisations of a decoding matrix for simple coding matrix of Fig. 4, using discrete transistors (a) and op-amps (b).



$$\theta = \tan^{-1} b/a = \tan^{-1} 0.382/0.924 = 22.5^\circ$$

Fig. 6. Geometrical visualization of simple coding method of Fig. 4 has the property of representing stylus motion in a disc groove. Modulations on the two groove walls are represented by L and R.

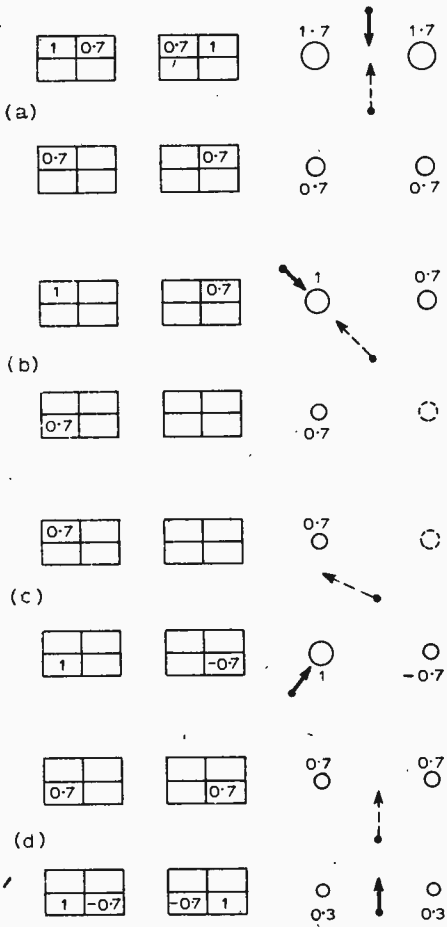

Fig. 7. Localization around 360° is not possible with simple matrix technique described. In this diagram, solid arrows show intended position of images and broken arrows show actual localizations. Four squares in each corner show wanted and unwanted outputs from each channel, which are summed in the diagrams on the right. Presence of antiphase signals causes mis-localization in the rear 270° sector, e.g. (c). Ambiguity exists for image intended for back centre, the signal appearing front centre (d).

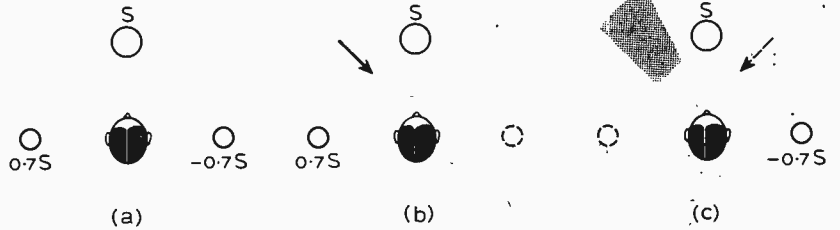

Fig. 8. Antiphase signals interfere with normal localization (Fig. 3) in the three-speaker situation (a). Left-most pair of speakers give an image shown by solid arrow (b), while right-most pair give an image somewhere in the shaded area, and not as shown by the broken arrow (c). The listener is shown facing one speaker for simplicity.

$L'_F = L_F(a^2 + b^2) + R_F(2ab) + L_B(a^2 - b^2)$   
 $R'_F = R_F(a^2 + b^2) + L_F(2ab) + R_B(a^2 - b^2)$   
 $L'_B = L_B(a^2 + b^2) - R_B(2ab) + L_F(a^2 - b^2)$   
 $R'_B = R_B(a^2 + b^2) - L_B(2ab) + R_F(a^2 - b^2)$

Assuming we want the two unwanted signals ( $R_F$  and  $L_B$  in the  $L'_F$  equation) to be equal (so that the image is central — Fig. 3) then  $2ab = a^2 - b^2$ . One solution of  $2ab + b^2 - a^2 = 0$  is  $a/b = \sqrt{2} - 1$  or 0.414 and substituting this value in  $a^2 + b^2 = 1$  gives  $a = 0.924$  and  $b = 0.382$ . This gives  $2ab = a^2 - b^2 = 0.707$ , so the final outputs are

$L'_F = L_F + 0.707 R_F + 0.707 L_B$   
 $R'_F = R_F + 0.707 L_F + 0.707 R_B$   
 $L'_B = L_B - 0.707 R_B + 0.707 L_F$   
 $R'_B = R_B - 0.707 L_B + 0.707 R_F$

A clear way of drawing the encoding matrix used in this example is shown in Fig. 4. The decoding matrix would be similar. Two convenient ways of realizing this decoding matrix circuit are shown in Fig. 5. These equations are in fact those of the Scheiber method<sup>3</sup>, one of the first matrices to be described.

We can look at it another way and a simple geometrical picture can be visualized for this kind of matrix by using the parametric form of the equation  $a^2 + b^2 = 1$ , i.e.  $a = \cos \theta$ ,  $b = \sin \theta$ . This allows us to think of the two transmission channels as the composite of the four input signals resolved onto two orthogonal axes representing the transmission channels — Fig. 6. This corresponds to the cutter or stylus motion in a disc groove. Although some writers have used this as a starting point in explaining matrixing, I have found it tends to confuse people. It is an incidental thing and has no equivalent in other two-channel media.

**Properties of simple matrix**

Crosstalk in this kind of matrix is infinite between the wanted channel and its opposite channel (e.g. the loudspeaker shown with a broken line in Fig. 3), because, for example, there is no  $R_B$  term in the expressions for  $L'_F$ . But crosstalk between the wanted channel and the two adjacent channels is  $a^2 + b^2/2ab = 1/2ab$  or  $a^2 + b^2/a^2 - b^2 = 1/a^2 - b^2$  which by substituting values of  $a$  and  $b$  is  $1/0.707$  or 3dB. in the case of the matrix described. This does not sound a lot but it's not as important in quadraphonic reproduction as in two-channel

because there are more than two speakers used in localization.

The crosstalk between the two front speakers would have a detrimental effect on localization between the two front speakers were there only two speakers. But in a quadraphonic array, with an input which would give an image just left of centre in a two-speaker set-up (7.7dB of crosstalk means the field would be reduced to  $\pm 12^\circ$ ), there is an output from the left back speaker, tending to pull the image further anti-clockwise. With a left front signal, equal amplitudes are emitted from the speakers either side of the left front one — resulting in good localization, Fig. 7b.

When the signal is to the left and back of the left front speaker, simple substitution in the equations shows that while the level of the left back speaker is increased and the level of the front speaker is reduced along with a reduction in the front left speaker, there is a signal in the back right speaker that is out of phase with the others, Fig. 7c. This shifts the image further away from the antiphase signal. How this antiphase component affects localization can be visualized by considering Fig. 8. Published experimental evidence is sparse, if not non-existent, on localization involving more than two loudspeakers, but we can get an idea of what happens by considering two different pairs of the three speakers in a three-speaker array. In Fig. 8(a) we wish to visualize the effect of the speakers with antiphase signals. In Fig. 8(b) it can be deduced from experimental evidence that for the two speakers shown the image will be at an angle of about 33 degrees<sup>4</sup> measured from S, shown by the arrow. In Fig. 8(c) the image position is not at the broken arrow, as would be needed for localization as in Fig. 3, but somewhere in the shaded area — it's difficult to show a precise location because there does not seem to be any exact data on this particular situation of Fig. 8(c). The point is that the presence of antiphase signals upsets localization.

In the case of centre back signal, cancellation in the equations for the back signals shows the image to be located centre front! — Fig. 7(d). The back centre signal, incidentally, whose image is in front, is smaller than a centre front signal by 7.7dB (1.707/0.707). Of course, it is impossible to get a defined image at centre

back anyway because the two back signals are in antiphase (see equations) and this prevents central image formation.

### Compatibility

As well as considering four-channel reproduction, it is important that matrixed recordings should give acceptable results when played through a conventional two-channel system. Fig. 9(a) shows the signals that would be fed to the two loudspeakers. Clearly if we had only a front signal to reproduce ( $L_B = R_B = 0$ ), the crosstalk is  $0.924/0.382$ , or  $7.7\text{dB}$ , which for speakers placed at  $\pm 30^\circ$  from a central axis narrows the field from  $60$  to  $24$  degrees<sup>4</sup> for speakers at  $\pm 45^\circ$  from  $90^\circ$  down to approximately  $34^\circ$ . Not very compatible!

Now, if  $L_B$  and  $R_B$  are not zero and  $R_F = L_F = 0$ , the effect of the unequal antiphase signals is to cause part of the stereo field to disappear from the middle region and to extend *outside* the location of speakers. The field can extend to  $\pm 90^\circ$  with equal antiphase signals and for  $L_B = R_B$ , the field extends to about  $\pm 53^\circ$ . (These angles apply if the listener is facing the antiphase speakers. When the speakers are behind, the apparent field width may be a third of its width.) Thus for material which has content in all four channels, the perceived width will depend on how much information is in the front signals and how much is in the back signals, and this is in the producer/editor's hands. But even though the wide-field antiphase components might be held to compensate for the narrow-field in-phase components, the result is clearly not the same as a conventional stereo record. At the same time it's quite possible that this is an effective substitute for a lot of people, some of whom may relish the antiphase effect, especially for reverberant sound and audience applause. (Applause is sometimes recorded in antiphase for pleasing effect in conventional recordings.)

In monophonic reproduction, Fig. 9(b), the antiphase signals partially cancel leaving the rear sounds  $7.7\text{dB}$  ( $1.306/0.542$ ) down on the front sounds — a severe fault in the system as it stands.

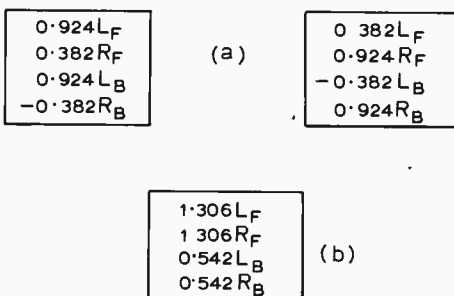

Fig. 9. Compatibility of a record coded using simple matrix with two-channel playback is illustrated at (a). Image field for front signals is reduced, but field for rear signals is widened because of antiphase relationship. In mono playback, rear signals are suppressed relative to front signals (b).

A second article will consider how the disadvantages of this simple matrix are overcome

### References and notes

1. 'Quadrphony and home video steal the Berlin show' *Wireless World* vol.77 October 1971 pp.486-8.
2. 'London Audio Fair' *Wireless World* vol.77 December 1971 pp.585-8.
3. P. Scheiber, 'Four channels and compatibility', *J. Audio Eng. Soc.* vol.19 1971 pp.267-79.
4. Angles are calculated according to data of H. D. Harwood in 'Stereophonic image sharpness', *Wireless World* vol.74 1968 pp.207-11.
5. Some argue that localization is the same with listener facing between speakers in Fig. 3, but the 'front source dominance' rule of Bauer *et al* that sound coming from the back of the listener sound is mostly heard after reflection and delayed sound does not influence localization due to the Haas effect. For the purpose of this article we assume head orientation through  $45^\circ$  has no effect.

B. B. Bauer, D. W. Gravereaux, A. J. Gust, *J. Audio Eng. Soc.* vol.19 1971 pp.638-46.

## New Books

**The Mazda Book of Pal Receiver Servicing** by D. J. Seal. Published by Thorn Radio Valves and Tubes Ltd, in association with Thorn Colour Tubes Ltd and W. Foulsham & Co. Ltd. Pp. 288. Price £3.50.

This book is an important one for those engaged in servicing colour television receivers using the PAL system and the shadow-mask tube. The editor of the book states that "It is assumed that the reader of this book has a sound knowledge of black-and-white television servicing and the PAL system". This must be emphasized.

The examples of equipment and circuits in the text are all drawn from two commercial types, the Decca CTV25 hybrid and the BRC 2000 all-transistor receivers.

The introductory chapter deals with similarities and differences between monochrome and colour sets. Chapter 2 is 'Installing a colour receiver'. In this are included degaussing, purity, static convergence and dynamic convergence adjustments. It is a great merit of the book that these are all well illustrated and that the important illustrations are in colour. The sequence of pictures of the cross-hatch pattern at stages of convergence adjustment is particularly good. There are, too, some excellent pictures which show the effect of poor grey-scale adjustments.

There is a chapter on colour test equipment and then, from p. 67 onward, the author, who is senior lecturer in charge of the Television Unit at Guildford County Technical College, takes the reader through every section of the receiver and the operation is briefly explained. After each such section faults are treated and in many cases their effects are illustrated by colour pictures. The treatment is in general terms and, as already mentioned, the details all relate to one or other of two specific receivers. The

details, of course, will vary with different designs, but the principles remain.

It is not possible to treat every possible fault that can occur, nor is it possible to cover every circuit variant. When working on a specific receiver the maker's service manual should be used, but this book with its wealth of colour pictures should be an invaluable supplement.

—W.T.C.

**HiFi Year Book 1972.** Contains specifications and prices of approx. 2200 audio products marketed under nearly 300 different brand names. A complete alphabetical index gives names, addresses and telephone numbers of audio manufacturers and distributors and also supplies brand names with the name of the firm responsible for marketing in the U.K. Supplementing the main directory section are articles covering a range of audio subjects. Pp. 376. Price £1.25. I.P.C. Electrical Electronic Year Books Ltd., Dorset House, Stamford Street, London S.E.1.

**Threshold Logic** by S. L. Hurst. Threshold logic and its realization in the form of threshold gates, offers a possible alternative to the usual Boolean approach and may make possible a considerable economy in numbers of gates and interconnections necessary in a particular logic circuit. An introduction to the subject is given, together with a suggested notation to differentiate between Boolean expressions and threshold equations. The use of threshold gates is discussed and covers complemented variables and functions, 'memory' applications, array networks, discrete component circuits and integrated circuits. Two chapters are on single-gate and multi-gate synthesis. Probable future developments in the field of threshold logic are outlined and also information for further reading and a short but useful glossary of technical terms. Pp. 78. Price £1.50. Mills & Boon Ltd., 17-19. Foley Street, London W1A 1DR.

**1972 Popular Tube/Transistor Substitution Guide** lists American and foreign types of transistors which normally need replacing in home entertainment equipment together with readily available and comparably priced substitutes. The guide comes in eight sections — four devoted to tubes and four to transistors — providing a cross section of American and foreign components with substitutes for popular component types found in commercial and industrial equipment. The most appropriate substitute is indicated in each case and there are base diagrams for all tubes and original type transistors. Pp. 256. Price \$4.95 (Vinyl) \$2.95 (Paperback). Tab Books, Blue Ridge Summit, Pa. 17214, U.S.A.

## Binding of *Wireless World*

Readers may like to know that our publishers will undertake to bind their copies of *Wireless World*. The cost, including postage on the completed volume, is £2.25. Copies should be sent to IPC Business Press Ltd, Binding Department, c/o 4 Iliffe Yard, London S.E.17, with a note of the sender's name and address. A separate note, confirming despatch and enclosing the remittance, should be sent to IPC Business Press (Sales & Distribution), 40 Bowling Green Lane, London EC1P 1AN.

For those who wish to bind their own copies cloth binding cases are available price 50p (including postage and packing) from the latter address. Readers will have noticed that the index for volume 77 (1971) was included in the December issue.

# News of the Month

## Automatic semiconductor testing machine

A machine for testing up to 10,000 zener diodes, rectifiers, thyristors or triacs per hour and for sorting the devices into one of thirty-six categories automatically has been developed by engineers at Mullard's Stockport semiconductor plant. The machine is called Apollo and has taken thirty months to build at a cost of about £80,000.

Devices to be tested are loaded into standard test jigs and are put into the machine by hand. From then on the process is automatic under the control of a Digital Equipment PDP8 computer. The route taken by the devices may or may not take them through an oven where they can be heated up to 130°C for 'hot tests'. The machine contains a number of conveyor systems and mechanical hands transfer the jigs from one conveyor to the next.

On their journey devices encounter a number of test heads which are designed to ensure that test voltages are not applied if the test head electrodes are not in proper contact with the lead-out wires of the device. Test voltages and currents originate from a bank of programmable power supplies under the control of the PDP8. The outputs of the test heads are

fed to an operational amplifier the gain of which is set by the computer. The output of the operational amplifier is converted to digital form by a high-speed analogue-to-digital converter and compared with measurement limits held within the computer. The scaling of the operational amplifier simplifies the analogue-to-digital converter design because the input voltage is now confined to a fairly narrow band.

The computer keeps track of each device through the machine and after all tests are completed ejects the device into one of thirty-six output bins depending on the test results. A photocell system counts each device as it falls into a bin and the bin total is compared with the number of devices the computer has assigned to that bin. If a discrepancy occurs an alarm is sounded and the machine stops.

The computer installation comprises an electric typewriter, the computer itself and a disc store. Typing the device number is all that is necessary to programme the machine. The results of one test on a particular device determine what the next test will be. The programme allows up to 24 separate tests with any number of limits per test providing that the total

number of limits does not exceed 124. The computer will calculate device yield or the mean and standard deviation of test results on a particular parameter, and will carry out a data logging function. Tests can be carried out at up to 250A or 2.5kV.

## The symbols Pa and S

The 14th General Conference of Weights and Measures (C.G.P.M.) was held recently in Paris. It was attended by delegates from 36 of the 41 member nations of the Metre Convention. The Convention, which was established in 1875 and to which Great Britain has adhered since 1884, has as its prime purpose the dissemination and the improvement of an international system of measurement. The Conference meets about every four years and at the Paris meeting unanimously adopted the names pascal (symbol Pa) for the SI unit of pressure (newton per square metre) and the siemen (symbol S) for the unit of electric conductance (reciprocal of the ohm).

## Stop television fires

The Fire Protection Association, a non-profit-making advisory organization on fire safety in the U.K., established 25 years ago, has appealed to the B.B.C. and ITV companies for help in reducing the 1,500 fires which break out in television and radio receivers every year. In a letter to heads of presentation and programme controllers, the F.P.A. asks them to make arrangements for fire safety warnings to be broadcast every night. In a letter, the F.P.A. says: 'the simplest and most effective precaution against fire in a mains television or radio receiver is to unplug it from the wall socket as well as switching off at the set. This will guard against a fault in the switch on the set itself, and also any fault in a wall socket switch'.

The letter points out that a TV set was thought to be involved in the 1969 Saffron Walden hotel fire where 11 people died.

'Vector', in 'Real and Imaginary' August, 1971, pointed out that the incidence of television receiver fires in the U.S.A. is also causing grave concern. In August 1969 a report from the Federal Government's National Commission said that 10,000 television receiver fires occur annually. The U.S. Electronic Industries Association strongly contested this figure and said a more realistic total would be 2,600 over a five-year period. Other reports put the figure somewhere between these two extremes.

One of these reports (Jitco) pinpointed the components that were most likely to go up in smoke. The line output transformer, not surprisingly, was the worst offender by a long way. Another astonishing figure produced by Jitco was that colour receivers are forty times more likely to cause a fire than monochrome receivers!

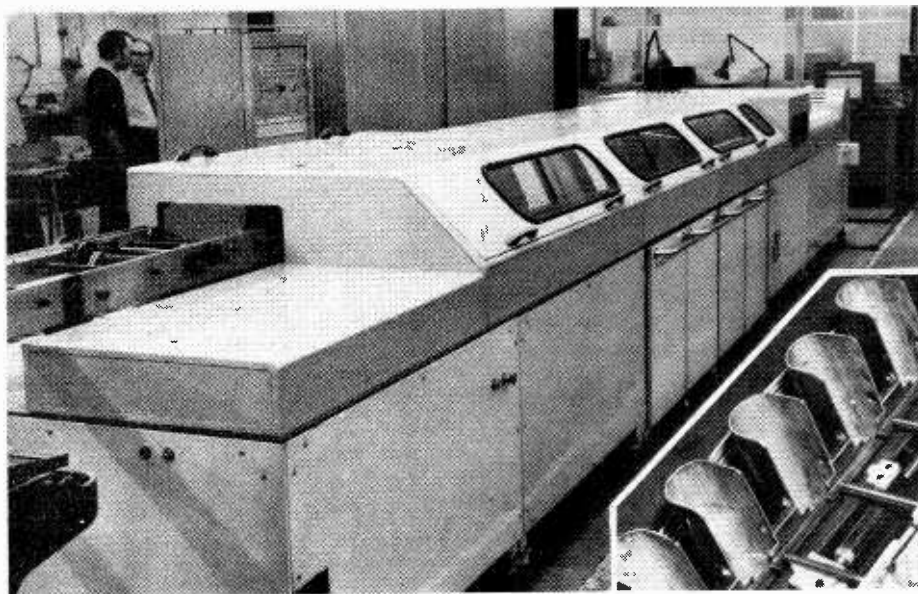

Mullard's semiconductor testing machine Apollo. Jigs containing batches of the devices to be tested are loaded into the rack on the left. The computer installation can be seen in the background. The insert shows five of the 36 shutes which lead to the output bins. Three of the solenoid actuated plungers which knock the devices out of the jigs into the shutes under the control of the computer can also be seen.

## "Remote blackboard" system

A new system, for transmitting and receiving handwritten information, encodes handwriting motions on a writing surface into bits of information, which are sent over ordinary telephone lines to a distant location. Dubbed as a remote blackboard, the system has been developed by Bell Laboratories in Holmdel, New Jersey.

A tiny, commercial location indicator, attached to a writing instrument, produces a steady series of ultrasonic pulses which are used to indicate the writing instrument's precise location, as it is moved over a surface bounded by two bar shaped microphones. The microphones are sensitive enough to accurately detect the location of the stylus at any point on the writing area and they generate a stream of electrical pulses. The pulses are then fed to a data set that converts them to signals easily transmitted over telephone lines. At the receiving terminal, another data set translates the incoming signals back to electrical pulses, to drive two galvanometers (rotating mirrors). The galvanometers are used to deflect an ultraviolet light beam to follow all the motions performed on the original writing surface. As the ultraviolet beam moves across a special photosensitive film, handwriting is reproduced, and can be simultaneously projected onto a wall or screen.

It is conceivable that the 'remote blackboard' system will be used along with a portable conference telephone, recently introduced by the Bell System, to transmit entire lectures with handwriting, sketches and diagrams to distant lecture halls and conference rooms. The system could also be used to bring classroom instruction to bedridden or invalid students.

## X-ray unit saves time

A fully automatic Faxitron 805 X-ray unit supplied by Field Emission U.K. Ltd, is being used to inspect a wide variety of television and audio equipment at the Chiswick, London, headquarters of Rank Bush Murphy. The unit, which enables high definition radiographs to be obtained on polaroid film, saves time and shows up faults which cannot be detected by other means and in addition provides irrefutable photographic evidence of internal faults. An instance of this type occurred when investigations were carried out into faulty capacitors. X-ray photographs revealed open circuits due to incorrectly soldered end connections. In another case checks on a sealed tape cassette showed that the tape was not routed correctly over a p.t.f.e. bearing causing wow and flutter.

## R & D expenditure

The U.K. electronics industry spent £122M, nearly 20% of its net output (sales minus fuel and material costs), on research and development during the year 1968-69. This was second only to the aerospace industry who spent 39% (£192M) of its net output on R & D. These figures are extracted from an analysis of industrial R & D expenditure published by the Centre for the Study of Industrial Innovation

*Last month Mr. M. Noble, Minister for Trade, officially opened a hybrid microcircuit factory for Beckman Instruments at Glenrothes, Fife. The factory covers 7,000 sq.ft. and contains both production and development areas. It is interesting to note that Beckman manufacture all their own resistive inks. The photograph shows a thermo-compression gold wire bonding machine at the factory. Mr Noble also opened a new 50,000 sq.ft factory for Beckman RIIC.*

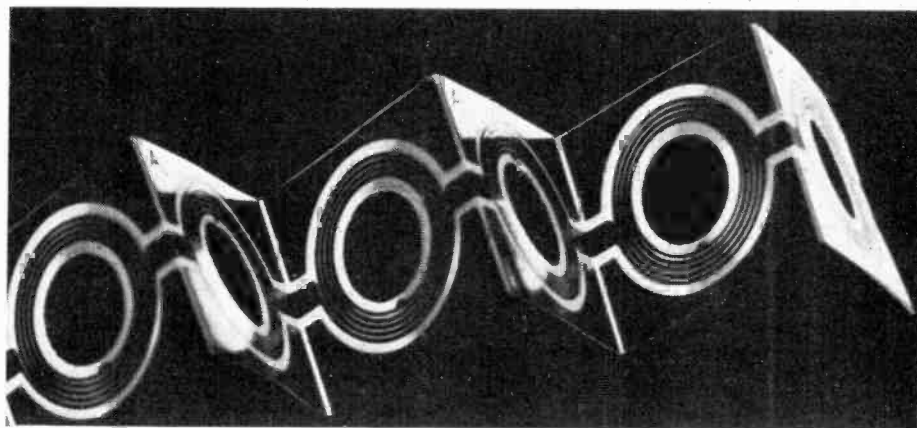

*A new printed coil assembly from Plessey. A series of interconnected coils are printed on each side of a polyester substrate which is then folded as shown. Washers are inserted between the folds and after bonding excess material is removed.*

*(Upper photograph, right). An X-ray photograph taken by the Faxitron equipment reveals that some of the capacitors in this batch are open-circuit due to incorrectly soldered end connections. (Lower photograph). One of the high-voltage rectifiers is seen to be faulty in this X-ray photograph of a colour television e.h.t. voltage multiplier. (See adjoining news item.)*

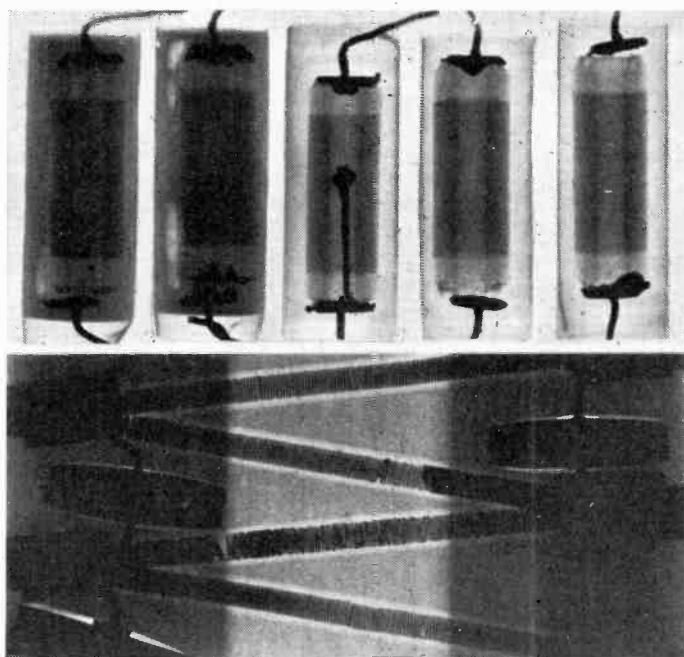

(copies of the report can be obtained from the Centre for the Study of Industrial Innovation, 162 Regent St., London W1R 6DD).

In contrast to these figures two-thirds of the 31 industrial fields analysed spent less than 4% of net output on R & D (marine engineering, tobacco, construction [only 0.1%], railways, domestic appliances etc.).

## Laser levitation

A laser beam has been used to lift and support small glass spheres in an experiment carried out at Bell Telephone Laboratories in America. In the experiment a laser was focused upwards through a glass plate on to a glass ball 20 $\mu$ m in diameter. Radiation pressure from light lifted the particle and held it captive in the beam. Initially it was found that the radiation pressure was insufficient to lift the ball due to molecular attraction between it and the glass plate (Van der Waals force). The attraction was broken acoustically by vibrating a ceramic cylinder attached to the plate. The glass sphere can be made to move up and down and sideways very precisely by changing the position of the focus of the laser beam.

## UK-4 in orbit

UK-4 was successfully launched from Western Test Range, California, by N.A.S.A. on December 11th using a four-stage solid fuel Scout launch vehicle. UK-4 is the fourth in the series of scientific satellites which have been part of a co-operative space research programme arranged between the British and U.S. Governments (UK-1 launched in April 1962 was the first international satellite). The project has been sponsored in this country by the Science Research Council and is expected to cost about £1.5M excluding the launch.

The five experiments on board are exploring the interactions between the plasma, charged particle streams and electromagnetic waves in the topside ionosphere. Important measurements will be made over the northern auroral regions during passes within telemetry range of the N.A.S.A. tracking station in Alaska.

In order to meet the requirements of an experiment from the University of Iowa (the first American experiment on a U.K. satellite) the spacecraft spin axis has to be turned through approximately 180° after launch, so as to point away from the earth's surface when the spacecraft passes through the northern auroral zone. This is accomplished by a magnetic torquing system which reacts with the earth's magnetic field and can be controlled from the ground.

The telemetry signal will be received by nine of the N.A.S.A. tracking stations and by the Radio and Space Research Station's telemetry station at Stanley (Falkland Islands). These stations record the data received from the satellite on magnetic tape together with timing and synchronizing signals; they also transmit to it any commands required. Most of the non-routine commands will be sent from the

We regret that continued increases in production costs necessitate raising the cover price of *Wireless World*. From the next issue it will be 20p.

Winkfield, Berks, station which is a collaborative venture between S.R.C. and N.A.S.A. and is operated for the Radio and Space Research Station by Airwork Services.

The radio carrier of the telemetry signal is modulated by bursts of tone lying between 5 and 15kHz at a rate of 55 bursts a second. It is these tone bursts which convey the data from the experiments and satellites systems, the frequency of the tone at any instant representing the value of the quantity then under observation. The measurements are transmitted as they are made. Concurrently some of the data are recorded on one of the two continuous-loop tape recorders carried in the satellite. On command from a telemetry station, the recorder speeds up and its signals are played back and transmitted to the ground.

The magnetic tapes from the telemetry stations will be sent to R.S.R.S. where they will be assessed, digitized and converted into computer compatible form.

To control the magnetic torquing operations, it is necessary to measure the pointing direction of the satellite spin axis in space; this will be done from the ground by the R.A.F. Satellite Tracking Unit using the satellite tracker radar originally employed by R.R.E. Malvern to measure the spin axis of UK-3.

Iowa University have provided an experiment, described as a low-energy proton and electron differential energy analyser which will measure the differential energy spectra of protons and electron intensities, separately, within the energy range 5eV to 50,000eV and will determine the angular distributions of low-energy charged particle intensities within the said range.

The results will be used for correlation with simultaneous v.l.f., h.f., and plasma measurements by companion experiments in the spacecraft.

An experiment labelled radio noise measurements in the MHz band from the Jodrell Bank observatory of Manchester University measures the radio waves generated by particle streams which are intimately related to the wave properties of the magnetoionic plasma. The generation mechanism considered to be involved is Cerenkov radiation, in both the magnetosphere and topside ionosphere.

The receiver operates in two modes, in one the frequency is swept from 0.75 to 4MHz in about 16 seconds and in the other a fixed frequency of 2MHz is monitored. The experiment can be operated in either of the above modes or can monitor alternate fixed and swept frequencies if required. The receiver bandwidth is 25kHz and dynamic range is 60dB. The experiment uses a dipole with a total length of over 40ft for signal reception.

In Sheffield University's experiment, the main interest lies in the very low fre-

quency electromagnetic waves which have been generated above the ionosphere as a result of various forms of instability that may occur there due to the presence of streams of energetic charged particles. The electromagnetic waves can be produced, for instance, by a transfer of energy from the gyratory motion of a charged particle to the electromagnetic field energy of the wave.

The Sheffield UK-4 experiment uses receivers covering a wide frequency range and will detect and measure these emissions and correlate them with other data, especially the particle measurements made by the Iowa group. It will also detect 'whistlers' generated by lightning discharges and will study the v.l.f. wavefield produced by the radio stations GBR (Rugby, U.K.) and NAA (U.S.A.).

In order to make these measurements, very sensitive receivers have been constructed to operate at 750Hz and 1250Hz with 500Hz bandwidth; at 3.2, 9.6 and 16kHz with 1kHz bandwidth; and at 16 and 17.8kHz with very narrow bandwidth. They cover a dynamic range of more than 70dB and are fed from a multi-turn screened loop aerial supported at the satellite boom extremities. The receivers were designed by the Sheffield University Space Physics Group and constructed by the Special Projects Division of Dunford Hadfields (Sheffield).

A local plasma density experiment and a local electron temperature experiment from Birmingham University records the electron density locally along the orbit using a sensor head consisting of two parallel grids carried at the end of a boom some 4ft away from the body of the spacecraft. The electron density is derived from a comparison of the electrical permittivity of the region between the grids measured at 39MHz. In order to ensure that the grids pass through space potential a voltage sweep from -6V to +6V is applied to them.

Measurements of electron temperature will give an independent identification of areas of intense particle precipitation, of the equatorial anomaly structure and possibly of the mid-latitude trough or plasma-pause. A pair of grids, similar to those used for the electron density experiment and on the opposite boom on the spacecraft will be used to measure the electron temperature in a derivation of the Langmuir probe technique.

A v.l.f. counter has been provided by R.S.R.S. as a small adjunct to the Sheffield University experiment. By correlation and counting of the peak reading signals obtained from the 3.2, 9.6, and 16kHz broadband Sheffield receivers measurements of v.l.f. impulsive noise is obtained. In this way lightning generated signals can be separated from those arising in the ionosphere and magnetosphere; the data might also provide information on thunderstorm distribution.

The spacecraft prime contractor was the British Aircraft Corporation, Electronic and Space Systems Group, and Marconi Space and Defence Systems was responsible for the satellite's electronic systems.



# Letters to the Editor

The Editor does not necessarily endorse opinions expressed by his correspondents

## Electrostatic headphones

Having used home-made electrostatic headphones of various designs for the past two years, I would like to raise several points concerning Mr. Harvey's article (November issue).

(1). I observe with alarm that the use of a transmission 'tunnel' between the drive unit and the ear is advocated, resulting in the formation of a cavity. Such a cavity, however carefully lined with absorbing material, is bound to give rise to resonances. One may point to the sharp kinks in the published response curves as evidence of these. Thus, in my own experiments any spacing between the ear and drive unit was rejected as causing unacceptable colouration; the sound becomes hollow and the extreme treble is lost (as indeed Koss admit in their literature). I have however obtained a satisfactorily open sound with a design where the perforated plates, which are circular (diameter 2½in), are held within a metal ring of L-shaped cross-section which presses them against the ear (separated only by a layer of plastic foam) but which itself has no acoustic function. This

contact with the ears is also the principle followed by Dr. Wilson (*W.W.* Dec. 1968).

(2). I can testify that headphones of this type are no mere amateur constructor's curiosity, as many people assume, but are capable of a quality of sound at least equal to that of the best loudspeakers. (Dr. Wilson perhaps did not make enough of this point.) Given this, justice will not be done to them unless the design of the accompanying electronics is to the standard habitually aimed at in power amplifiers. Now a simple calculation, using the given dimensions of 75 × 45mm and 2 × 0.37mm spacing, gives a capacitance between the plates (if air-spaced) of 40pF. As a large part of the plate area is covered by the plastic spacers ( $\epsilon > 1$ ) this will be increased, and wiring also makes an important contribution; thus in my present design it amounts to some 150pF. This is equivalent to twice the capacitance from either plate to earth, as they are driven in push-pull. So with the 120kΩ output impedance of the published valve amplifier the treble response will be -3dB at 16kHz for 40pF, or 4kHz for 150pF, etc.

Even if a low output impedance is obtained by negative feedback, the available output signal is still correspondingly restricted at these frequencies. Now of course the treble on commercial long-playing gramophone records is in any case severely limited, but it may be predicted that after using these headphones for a time one will want to listen to signals of better quality (e.g. tape recordings from microphone), and then this will be found to be inadequate. So, to improve the treble output, the valve anode current should be made as large as possible — limited by the valve's power rating.

Furthermore, the distortion from the valves can reach 5 or 10% as the input is increased and still not be 'observable on an oscilloscope'. (In the transistor amplifier the long-tailed pair will generate even greater distortion as full output is approached, owing to the absence of any negative feedback.) A figure of 0.1% is not an unreasonable one to aim at and as a first step in this direction I can suggest the output stage in Fig. 1.

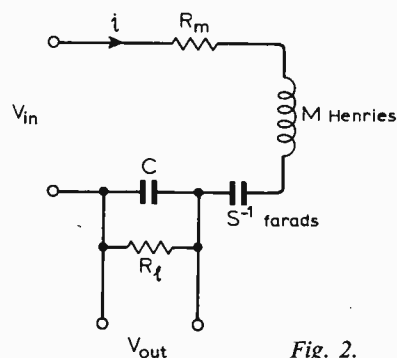

Fig. 2.

The distortion now comes mainly from the transistor, and at 90% of full output was measured as 1%; it can be reduced to 0.2% by removing the 10 μF capacitor, if the previous stage can provide a signal of 20V pk-pk. When the valve was driven at the grid in the ordinary way the distortion was 10% for the same output. The negative feedback also yields a low output impedance and a very useful rejection of h.t. line hum.

The overload recovery of the circuit shown in Fig. 1 is good, and this, together with the excellent transient response of the headphones, results in the curious observation that momentary clipping of the signal goes unnoticed by the listener.

(3). Finally, Mr. Harvey's calculation of expected frequency response goes somewhat astray. The figure of 0.5Hz as the low-frequency -3dB (not -6dB!) point might be obtained if the diaphragm were half a mile or so in extent, but for sizes  $\ll \lambda$  the air escapes around the edges and so presents a much lower impedance to the diaphragm's motion. If this were not so the 55Hz resonance could not be observed! Fortunately, in the presence of the ear the l.f. loading is different again, and becomes a capacitance (C) in series with  $R_m$  in his Fig. 19 (see Fig. 2). Hopefully  $C < S^{-1}$ ,

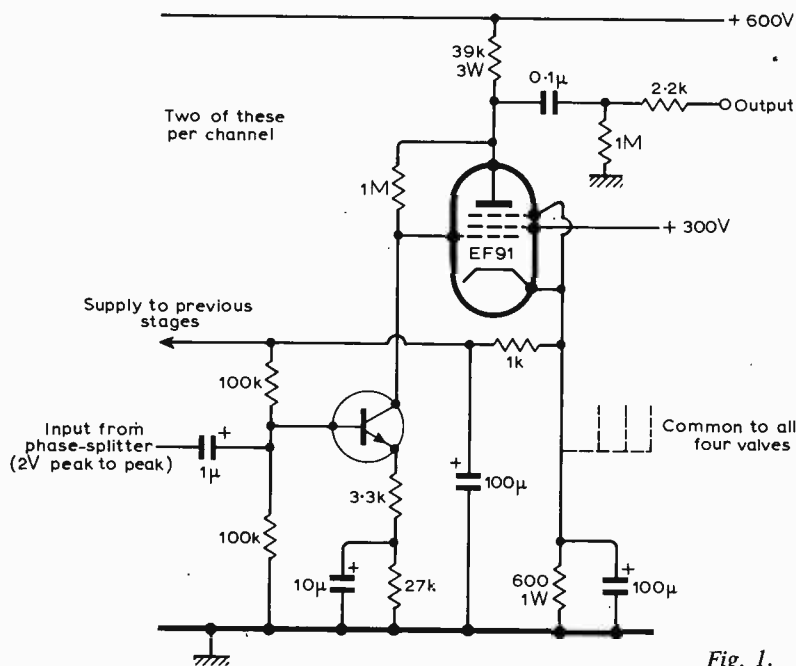

Fig. 1.

which is another reason for avoiding a cavity. The ear now responds to  $V_{out}$  (i.e. pressure), not  $i$  (i.e. diaphragm velocity), so that the response is flat down to a frequency determined by air leakage ( $R_1$ ) due to imperfect sealing between 'phones and ears. Thus to obtain good bass response padded muffs would be desirable, though designed so as not to affect the contact with the ear on which low colouration depends.

Incidentally, theory indicates that while constant-charge operation certainly is important to obtain low distortion, the small-signal sensitivity is the same as for constant-voltage operation; thus one queries the statement that bass response improved as the diaphragm resistivity was increased.

J. HALLIDAY,  
Cavendish Laboratory,  
Cambridge.

## Power supply for f.m. tuner and decoder

The following power supply circuit is suitable for the *Wireless World* phase-locked loop stereo decoder and f.m. tuner circuits published recently. The latter requires a very low ripple power supply if there is not to be hum on the output signal.

A 'shunt' zener system is used as this is thought less likely to give an over-voltage failure, which could prove expensive with both tuner and decoder connected. A cascade system of constant current sources achieves ripple isolation, and is similar to Peter Williams' 'Ring of Two' circuit. The circuit features re-entrant overload protection, and is short-circuit proof. The  $15k\Omega$  resistor  $R_1$  gives starting current, and  $R_2$  is adjusted with a resistive ( $100\Omega$ ) load to give minimum ripple on the output. It is necessary to use a resistive load because switching transients and audio can mask hum measurements. With  $C_1$  and  $R_2$  omitted and a  $100\Omega$  resistive load, the hum and noise on the output is  $<0.5mV$  r.m.s. This figure is reduced to  $<0.03mV$  r.m.s. by  $C_1$  and  $R_2$ .

In operation, with both tuner and

decoder connected there is approx.  $0.9mV$  noise at the supply output, this being switching noise and audio. This may be reduced by the addition of further capacitance at the output terminals:  $1000\mu F$  reduces the figure to  $0.15mV$  (mainly audio), but makes no audible difference.

A practical note — in order not to degrade the low ripple content, the output d.c. leads should be twisted together and kept away from the mains transformer. Drift is minimized if  $Tr_1$  and the zener diodes are mounted on generous heat sinks.

It is thought that versions of this circuit (with  $R_2$ ) will be of use to generate a reference voltage for power supplies, as complete compensation for mains changes will be possible if  $C_1$  is replaced by a short-circuit. This was not done as it makes the design of the starting circuit more difficult, when, as in this case, the circuit has to supply relatively high current to a load. The starting circuit will be simple if, as in this design, the circuit has to supply only low current when used as a reference voltage.

P. LACEY,  
Crediton,  
Devon.

## F.M. tuner bandwidth

I would like to express my agreement with Mr. R. G. Mellish (December issue p.584) on the subject of f.m. tuner bandwidth. His views on the subject appear to coincide with my own. However, I venture to disagree with him on the value and practicability of mathematical analysis. The writings of Mr. Nelson-Jones provoked me into investigating the possibility of analysing i.f. filter performance and, as a spare-time entertainment, I have been writing a computer programme to do so in a very comprehensive fashion. At the time of writing, the programme is complete and testing is about to start. The problem was not quite as mind-boggling as Mr. Mellish seems to think, though the programme is admittedly a large one.

Basically, the programme takes as input a signal consisting of a multiplicity of sinusoids and computes the discriminator output spectrum (complete with phase

information). Limiting is assumed to be perfect and the discriminator distortionless. The filter is specified in terms of  $Q_s$  and  $Q_k$  or alternatively in terms of pole positions. There is a switching-type stereo decoder tacked on the end, so to speak. The purpose of the programme is to investigate the effect of the i.f. filter on receiver distortion and stereo separation. It could also be used to examine the effects of receiver mistuning.

The value of experimental work lies in checking that the model has been programmed correctly, and afterwards in checking that any filters proposed perform as predicted. Apart from that, it is redundant. The computer can analyse filter performance with an immensely greater precision and speed than is possible by experiment. Listening tests are of value in determining what performance criteria to apply as regards distortion, stereo separation, interference rejection or whatever, and again as a final check.

As a matter of interest, the first filter I propose to investigate is that used in Mr. Nelson-Jones' tuner design, and I also hope to obtain some objective measurements from a receiver built using these filters. The results should be quite fascinating!

J. E. A. FISON,  
University of Bradford.

## Pre-amp for ceramic pickups

Intending constructors of the economy pre-amplifier for ceramic pickups (*Wireless World*, August, page 379) may find the following points helpful.

For mono use of a stereo pickup, parallel the two channels of the pickup as usual and connect direct to the pre-amplifier. No component changes are needed.

For very high output pickups, e.g. Acos GP93/1 which gives  $280mV/cm/sec$ , suitable values for  $C_1$  and  $C_2$  are  $27nF$  and  $4.7nF$ , respectively.

Transistor voltages, measured with Av0 8 (20,000  $\mu V$ ) are:

	E	B	C
$Tr_1$	1.2	1.2	4.5
$Tr_2$	2.5	3	11.5
$Tr_4$	1.1	1.5	14

Unfortunately some errors crept into the circuit on page 379. The emitter bypass capacitor of  $Tr_2$  should be  $50\mu F$ . The capacitor in series with the upper end of the  $20k$  'Treble' control labelled  $0.1F$  should be  $0.01F$ . The connection from  $Tr_3$  collector to the volume control is shown direct. There should of course, have been a  $1F$  capacitor to block d.c. from the volume control as in the circuit on page 382.

Finally on page 382 a capacitor is marked  $6.800p$  — it should have been  $6,800p$ .

B. J. C. BURROWS  
Ewelford,  
Oxford.

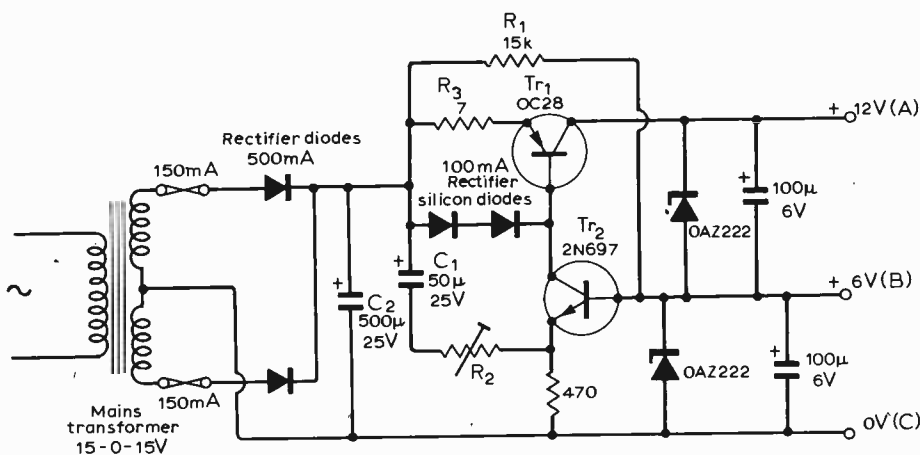

Power supply circuit. Adjust  $R_2$  (which is approx.  $8k\Omega$  — using  $5.6k\Omega$  and  $10k\Omega$  potentiometer) for minimum hum. Suggest  $10\Omega$  and  $22\Omega$  in parallel for  $R_3$ .

**The Liniac**

I would like to make a few comments on J. L. Linsley-Hood's article, 'The Liniac', *Wireless World*, September 1971.

He describes a transistor circuit which may be used to obtain a high dynamic voltage gain, coupled with a low distortion figure.

The low distortion figure is entirely due to the fact that the collector current of the amplifier transistor is modulated by only a small percentage of the quiescent value. As a result the excursion of the amplifier transistor is limited to a small, and therefore approximately linear, portion of the input characteristic of the transistor. As Mr. Linsley-Hood points out, the non-linear input characteristic is the main cause of distortion in small-signal bipolar transistor circuits.

I would like to point out another circuit which, while exhibiting gain figures of the same order as the liniac, uses only a fraction of the number of components required for a liniac.

The circuit is shown in Fig. 1, and obviously functions in a way similar to the liniac. A directly-coupled bootstrap action accounts for the missing field-effect transistor, at no cost to the final performance of the amplifier.

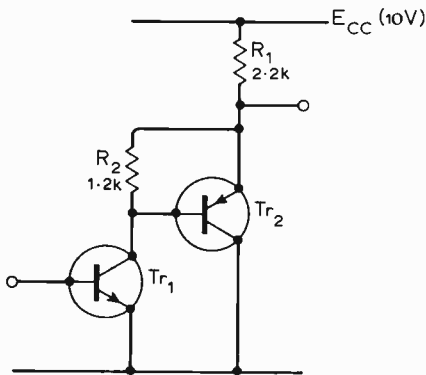

Typical voltage gains measured for the circuit were of the order of 1500, in good agreement with theoretical values. If a high-gain transistor (or Darlington pair) is used for  $Tr_2$ , the voltage gain of the circuit is limited by the parameter  $h_{oe}$  of transistor  $Tr_1$ .

As is the case with the liniac, this circuit also exhibits a low distortion figure.

In contrast to the liniac, the frequency response of the circuit is nearly an order of magnitude better, with a 3dB bandwidth of approximately 100kHz. This is due to the much lower input impedance of the circuit. If Darlington pairs are used for the two transistors in the circuit, performance should be similar to that of the liniac. The saving of one f.e.t. should leave no doubt as to the superiority of the circuit.

An approximate expression for the voltage gain of the circuit is given by the formula

$$A_v \approx -g_{m1} R_L'$$

where  $g_{m1}$  is the mutual conductance of transistor  $Tr_1$  (approximately  $I_{E1}/25\text{mA/V}$ , where  $I_{E1}$  is the emitter current of transistor

$Tr_1$  in mA), and  $R_L'$  is the dynamic load of this transistor, given by the formula

$$R_L' = \frac{h_{ie2} h_{fe2} R_1}{h_{oe1} h_{ie2} h_{fe2} R_1 + h_{ie2} + R_2}$$

which simplifies to

$$R_L' \approx \frac{1}{h_{oe1}}$$

if

$$h_{ie2} + R_2 \ll h_{oe1} h_{ie2} h_{fe2} R_1.$$

A simple modification to this circuit makes it possible to obtain a high input impedance for the amplifier. In the circuit shown in Fig. 2, the input impedance will be

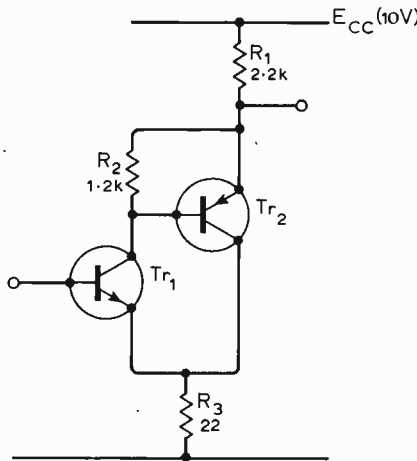

of the order 200kΩ, assuming transistors with current gains of the order 150 to 300 are used in the circuit. The voltage gain of the circuit is then given approximately by the formula

$$A_v \approx -\frac{R_1}{R_3}$$

which is 100 for the circuit shown.

The choice of the resistor  $R_2$  (2.2kΩ in both circuits) is governed by the parameters  $g_m$  and  $h_{oe}$  for transistor  $Tr_1$ . Assuming sufficiently high current gain for transistor  $Tr_2$ , the voltage gain of the circuit in Fig. 1 is given approximately by the formula

$$A_v \approx -\frac{g_{m1}}{h_{oe1}}$$

The collector current of the first transistor should therefore be chosen so that the ratio of  $g_m$  to  $h_{oe}$  for this transistor is a maximum. For most transistors this ratio remains more or less constant for a wide range of values for quiescent collector current, so that the choice is not a critical one. Bearing in mind that  $h_{oe}$  increases with collector current, the collector current of transistor  $Tr_1$  should not be too small, as this puts a more stringent requirement on the current gain of  $Tr_2$ .

The resistor  $R_2$  is then given by the formula

$$R_2 \approx \frac{0.6}{I_{C1}}$$

where  $I_{C1}$  is the required quiescent collector current of transistor  $Tr_1$ . The assumption is made that silicon transistors will be used in the circuit, with a base-emitter voltage of

approximately 0.6V at the biasing point of  $Tr_2$ .

The amplitude of the output voltage of the stage is limited to the point where  $Tr_2$  approaches cut-off.

Biasing networks similar to those discussed by Mr Linsley-Hood for the liniac may be used for this circuit.

At the University of Stellenbosch we use the name 'antisymmetrical pair' for the circuit. This could perhaps be abbreviated to 'The Asp'.

P. W. VAN DER WALT,  
University of Stellenbosch,  
South Africa.

**Improving ceramic pickup performance**

Some of your readers may be interested in a modification to a commercial radiogram to improve the performance of the ceramic pickup cartridge. An add-on amplifier is incorporated using the virtual earth technique described by B. J. C. Burrows in the August 1971 issue of *Wireless World*.

The components to the left of the dotted line in Fig. 1 are replaced by an active compensation circuit. At present more output is obtained on radio than from records so it would be desirable to provide 6-8dB more gain. The passive correction circuit has an insertion loss of  $\approx 20\text{dB}$  hence the loss of the new circuit should be about 12dB. There is sufficient l.f. cut in the main amplifier that additional rumble filtering is not required. However, simple l.f. and h.f. roll off is provided to define the passband limits.

Allowing 200pF for the capacitance of the screened lead the total capacitance associated with the pickup is given by:

$$C = 200 + 800 + 2200 = 3.2\text{nF.}$$

Taking 500Hz as the break point, the input circuit CR should be  $318/\text{s}$ .  $\therefore R = 100\text{k}$ . To compensate for the inadequate mechanical correction provided within the Sonotone 9TAHC Mr. Burrows suggests that  $R_1 = R/1.8 = 56\text{k}\Omega$ . The attenuation of the input signal due to  $C_1$  is:  $800/3200 = 12\text{dB}$ .

To ensure an overall loss of 12dB let  $R_2 = 68\text{k}$ . Again  $318/\text{s}$  time constant is required for the feedback circuit, therefore  $C_3 = 4.7\text{nF}$ .  $C_2 = 1.50\text{pF}$  is added across  $R_2$  to provide h.f. roll off above 15kHz. Similarly  $R_4 = 1\text{M}\Omega$  is added across  $C_3$  to increase the attenuation below 35Hz.

A collector current of  $100\mu\text{A}$  is selected for  $Tr_1$  being a compromise between low noise and high signal handling. For a  $V_{ce} = V_b/2$ ,  $R_5 = 56\text{k}$ . Assuming  $h_{FE} = 200$  for the transistor, the required base current will be 0.5 A. Approximately 5 A will flow through  $R_4$ , therefore the surplus must be shunted through  $R_3$ , giving:

$$R_3 = V_{be}/(4.5, 10^{-6}) = 150\text{k}$$

The parallel combination of  $R_5$ , the feedback network and the load due to the

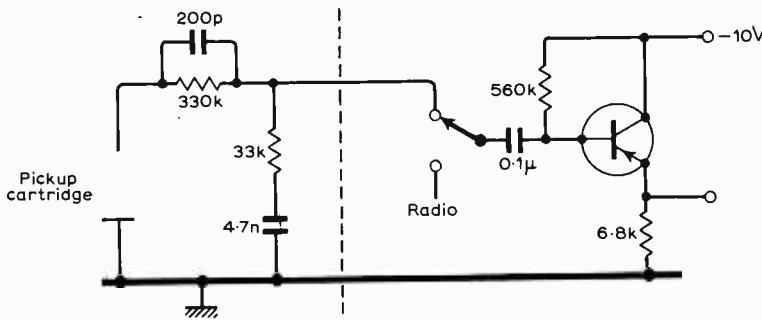

Fig. 1.

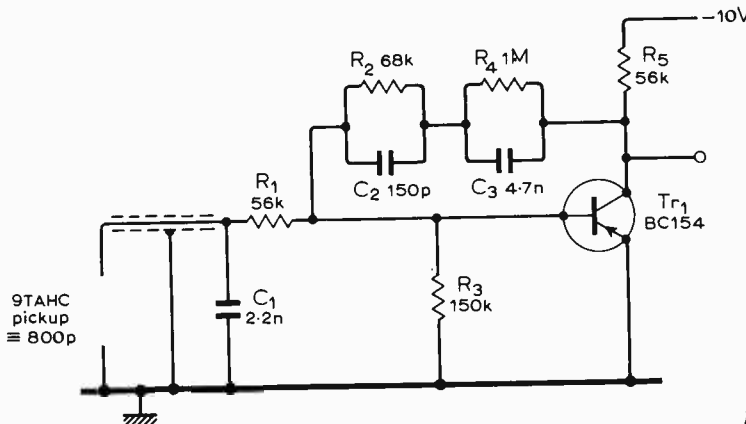

Fig. 2.

following stage is  $\approx 22k'$ , giving an output swing of:

$$V_o = 22 \cdot 10^3 \cdot 100 \cdot 10^{-6} / \sqrt{2} = 1.5V \text{ r.m.s.}$$

Cartridge output is quoted as 55mV/cm/sec but it is possible for this to be exceeded by 20 times on full modulated "pop" recordings, giving an output of about 1.1 volts. This represents an amplifier output level approaching 400mV, giving a worst case overload margin of 12dB.

The frequency response is shown in Fig. 3. This is measured by feeding an audio generator to the input via an 820pF capacitor to simulate approximately the ceramic pickup.

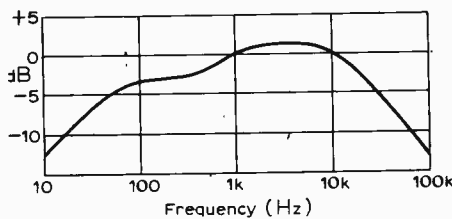

Fig. 3.

Total harmonic distortion is  $< 0.5\%$  over the range 100-8000Hz; this being the limitation of the measuring equipment.

The circuit has been checked up to 50°C ambient temperature and apart from the collector voltage falling by 20% there is no noticeable change in performance. Metal oxide resistors  $\pm 5\%$  tolerance are used together with  $\pm 2\%$  silver mica capacitors. Layout is not critical, both left and right channels being constructed side by side on a piece of Veroboard.

G. H. BAKER,  
Romford, Essex.

### More or less power for amateurs?

It is proposed in "World of Amateur Radio", page 511 of the October issue, that British amateur transmitter power limits be raised above the present 150W d.c. and 400W p.e.p., the reason being that higher limits in other European countries make an increase necessary to maintain a balance in international competitions. I am somewhat disappointed by this approach, and would suggest that it is now preferable to consider a worldwide reduction of permitted power levels. The advent of more sensitive receivers, more stable transmitters, and more efficient aerials and modulation techniques makes such a move possible. Indeed, increased use of the spectrum may thrust this solution upon us.

Coming from a Canadian amateur, this proposal must sound like "sour grapes" (the Canadian power limit is 1kW); however, having been moved by the *W.W.* article to express my views, I intend to pursue the matter with the Canadian Amateur Radio Federation also. Further, I have never operated a station at more than 100W d.c. or 180W p.e.p., and have enjoyed operating immensely except when submerged (frequently) by high-power stations.

It may seem easier for Canadian and U.S. amateurs to find space for high-gain aerials (and maintain a power advantage) than it is for many European operators. I have never been permitted by Canadian landlords to erect anything more efficient than a dipole (last year, in Ottawa, I could mount only a multi-band vertical at ground level), but I have encountered no restrictions in two postings

to Germany; so from personal experience North America offers no advantages over Europe.

I hope you will find it possible to sponsor a move to lower power and influence all countries in this direction.  
C. E. HOOKER,  
(DA2XC/VE3CQH, ex-DL2AD),  
Mannheim,  
Germany.

### Our contributor replies:

As I made clear in October, few British amateurs would disagree with Mr Hooker's views on the undesirability of high-power operation. Unfortunately, the chances of an international agreement to reduce power in this way seem extremely remote. Most of us believe firmly that 150 watts (r.m.s.) is a reasonable level — and there should always be plenty of opportunity of using effectively far less than this. But in the meantime, power levels generally in Europe seem to be rising rapidly towards the kilowatt region, and the fact remains that British amateurs are now at a significant disadvantage.

PAT HAWKER.

### Differential discriminator circuits

Readers might be interested to know that a circuit similar to that described by H. A. Cole in your December 1971 issue page 603 was flown in the Skylark rocket X-ray astronomy experiment by Professor A. P. Willmore (see page 576 of the same issue). A solar X-ray experiment by W. M. Glencross and D. Brabban, of this laboratory, using this type of discriminator was also flown in September 1969 aboard an ESRO Skylark rocket from Sardinia.

The circuits flown differed from that of H. A. Cole's Fig. 1 only in that the input was positive-going, points marked  $V_H$  and  $V_L$  were grounded; discriminator levels being set by the feedback resistors  $R_3$ . Because the input was positive-going inverters  $G_1$  and  $G_2$  were not included.

Two problems were encountered with this arrangement. First, the input needed to be a.c. coupled with a short time-constant so as to ensure that the circuit once tripped would reset. Secondly, current spikes generated by the t.t.l. logic tended to cause the lower level discriminator to keep on firing if set below 50mV. This was overcome by the use of low-power t.t.l. logic and careful p.c. board layout. It was found that levels down to 2mV could be set if a low-power t.t.l. gate was included within the feedback loop and the amplifier inverting and non-inverting connections reversed. Hence, the use of a high gain pre-amplifier can be avoided.

Finally, a further Skylark experiment is now in preparation for J. L. Culhane which uses five LM211D comparators (National Semiconductors) in a similar arrangement to form a four-channel pulse-height analyser as shown in the diagram. Because the levels are not acquired simultaneously a four-bit register is used to store

Four-channel pulse-height analyser to which R. W. Penny refers.

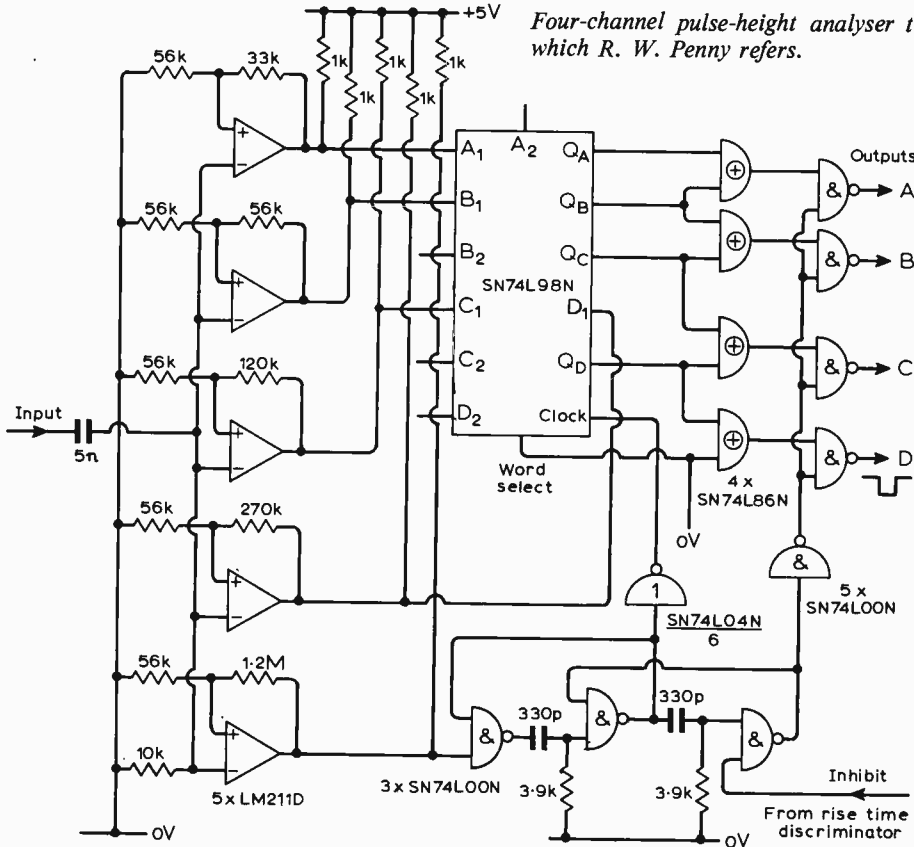

the state of the four upper-level discriminators. The timing circuit is initiated by the lowest-level discriminator and strobes the register output into four exclusive-OR gates. In this manner a unique output is obtained for a particular pulse-height band. The circuit has the advantages of speed and simplicity over the conventional analogue stretcher followed by A-D converter circuit although for more than seven channels it becomes wasteful of power and volume. The LM211D comparator was used because of its low power consumption and high input impedance although it is more costly and somewhat slower than the 710 series of comparators.

R. W. PENNY,  
Mullard Space Science Laboratory,  
University College, London.

### Multiplex TV Transmitters

In the news item "Multiplex Operation of Television Transmitters" in your December issue, it is stated that the B.B.C. is unlikely to use correction techniques to minimize unwanted products when klystrons are operated as combined sound and vision signal amplifiers.

This conclusion is, however, incorrect as the Corporation might well adopt such arrangements. The possibility of doing so was referred to in the article "Multiplex System for Standby Operation of UHF Television Transmitters" in *B.B.C. Engineering* No. 85, January 1971, and also in the article "UHF Relay Stations" in *B.B.C. Engineering* No. 88, October 1971. L. W. TURNER,  
B.B.C.  
London.

### Digital frequency meter mods

You might be interested to know that at little extra cost or complexity Mr. Attenborough's counter (December issue p.597) can also be used as an a.f.c. unit to correct any drift in the local oscillator of the associated receiver. I have been working on this system for some time, but due to ill health progress has been slow. Last year I sent an interim report to the R.S.G.B., and have had a semi-breadboard (logic cards complete but display, intercard wiring and some control circuits only in temporary form) working and have proved the system; I am now building the cards and display into a cabinet.

The system works in two modes 'tune' and 'frequency lock'. In the tune mode the oscillator frequency is measured and allowing for i.f. offset the aerial frequency is displayed. The circuit is very similar to that proposed by Mr. Attenborough. In the frequency lock mode the strobe to the 7475 stores is cut off. The display will now continuously show the required frequency, the rest of the counter runs as normal but at the end of each counting period the frequency measured is compared with the required frequency held in the stores. If due to oscillator drift they are not the same an a.f.c. voltage is generated which, via a varicap diode, corrects the oscillator frequency.

There are various ways of comparing the ÷10 counters and the 7475 stores. What, I think, is the simplest way and the one I have used, is to set the ÷10 stages to 9 minus the figure held in the associated store before the start of each count. If there has been no drift of frequency the ÷10 counters will all end up on 9 or

some other fixed figure if an i.f. offset has been used. The main point is that the figure will always be the same, irrespective of the actual frequency displayed, and if some other figure is generated this indicates a frequency error and with suitable logic an a.f.c. voltage can be generated. The frequency error will immediately show up in the least significant ÷10 and it is only this one that need be set to 9 minus store; all higher order stages can be switched off or ignored. The ÷10 counter can be set to 9 minus store by generating the 9s complement of the figure held in the store. The following truth table is used:  $a = \bar{A}$ ,  $b = \bar{B}$ ,  $c = \bar{B}C$ ,  $d = \bar{B}C\bar{D}$ . ABCD are the output of the store and abcd is used to set the ÷10.

The conversion of the detected error into a d.c. voltage suitable for the varicap diode can be done in various ways. The drift characteristics of the oscillator governs how complex the system need be. A simple method that can be used with reasonably stable oscillators and where the least significant figure of the i.f. offset is zero is as follows:— The varicap diode is fed from an integrator; when the count of the ÷10 is 9 (no frequency error) zero volts are applied to the integrator. When the error is high or low a plus or minus voltage is applied. The integrator output will drift and the varicap will alter the oscillator frequency to correct the error. With a 8421 count the direction of error is shown by the state of the C or D outputs, this will give '0' for the counters of 0-3 and '1' for counts of 9-4. The former indicates frequency high and the latter frequency low. This method used with a counter whose last decade is tens of Hz will correct drift rates up to about 70Hz/sec. In more difficult cases extra logic will be required. In some cases it may be necessary to take error information from the next ÷10 stage before the least significant one and this stage must then be set to 9 minus its store.

To sum up, this system of frequency control of a local oscillator (or any other oscillator, e.g. a signal generator) can be included in any counter provided a store is used between the ÷10 stages and displays and that the least significant ÷10s can be preset to any number. The logic required to generate the 9 minus store and detect the frequency error will not add all that much to the logic required for the normal counter.

JULIAN GARDNER,  
Southampton,  
Hants.

Displaying Frequency Digitally by C. Attenborough, December 1971. Please make the following amendments: Fig. 2. The 7473 should not have a clear input and there is one too many 7490s in the divider chain. In the first line of text on page 599 10M should read 10<sup>M</sup>

# Horn Loudspeaker—Mk II

by John Greenbank \*

When details of the first version of the low-cost horn loudspeaker† were published the design had proved itself but the appearance of the system left a lot to be desired. Of course, any would-be constructor who grasped the essentials could make numerous superficial

\* Assistant editor, *Wireless World*.  
 † 'Low-cost horn loudspeaker system', 'Toneburst', *Wireless World*, May 1970. Tearsheets of this article are still available price 12½p.

alterations, but the width of the treble horn was something of an embarrassment. It was decided therefore to proceed with further investigations with a view to streamlining the appearance. The first step was to abandon concrete. For several reasons concrete is almost the ideal material, but at domestic listening levels, where pressure changes in the system are relatively small, the structural elasticity of a well-made plywood horn should be of

little consequence. If the bass horn is constructed for low-frequency reinforcement in a large hall, say when used with an electronic organ, it might be sensible to use heavily braced chipboard or even the original concrete version.

Other changes in the system are as follows—

1. reduction of the internal width of the bass horn to that of the driver chassis diameter;
2. reduction in depth of the bass horn;
3. reduction of treble horn width by trimming the sides of the horn but maintaining the length according to the expansion law involved; and
4. modification of the crossover circuit giving improved high-frequency performance.

### Construction of bass horn

The front, the sloping top and bottom, the back 'corner' panels and the speaker board are made from 12mm plywood. The front panel is removable. Other wood items can be 9mm ply. All joints should be made with a p.v.a. adhesive such as Evostik Resin 'W'.

Structural details are given in Fig. 1. In this version the Fane 122/12 driver is

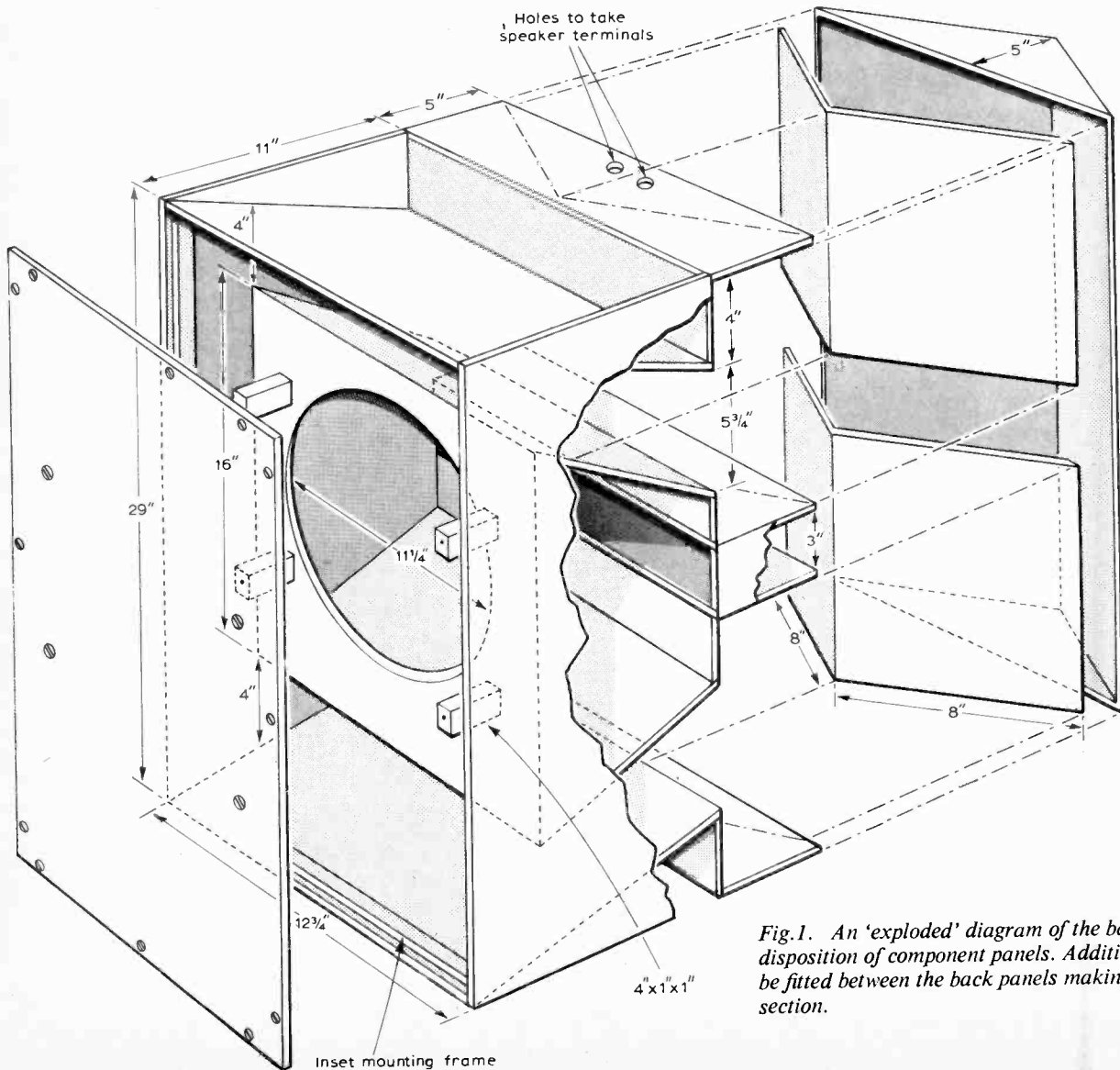

Fig. 1. An 'exploded' diagram of the bass horn showing disposition of component panels. Additional bracing should be fitted between the back panels making up the corner section.

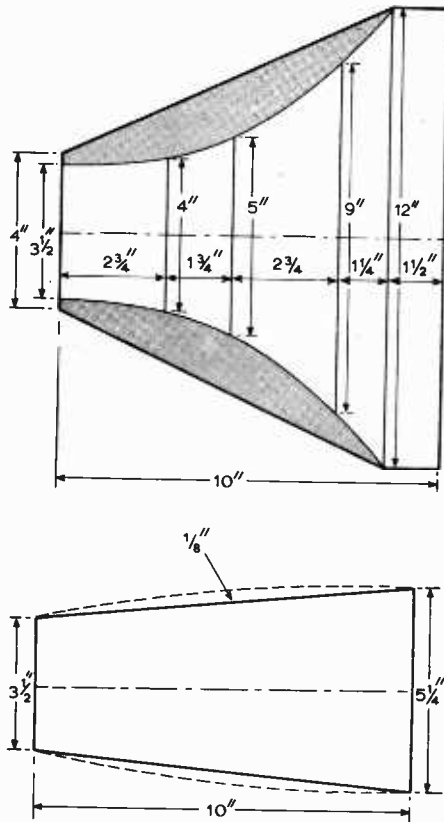

Fig. 2. Details of wood sections used in constructing the treble horn. The side sections should be cut along the curve shown dotted (see text).

mounted from the front against a strip of rubber which should be fixed on the front of the board round the edge of the 1 1/4 in diameter hole to provide an air-tight seal. The front panel does not need a seal but the inset 1 x 1 in mounting frame should be firmly glued in place, and will need chamfering in the top and bottom positions.

Before the triangular corner section is attached, airtight speaker terminals should be fitted. Connecting wire is soldered on and fed through the back-of-cone chamber out through the hole in the speaker board. The wire should be soldered to the tags on the drive unit and the drive unit screwed down tightly.

Four 4 in bracing posts, cut from 1 x 1 in wood should be stuck on to the speaker board, round the drive unit, using p.v.a. adhesive. When the joints are dry paint the ends (with poster paint for example) and press the front panel up against them. Remove the panel, mark its top, and drill through at the centre of each area of transferred paint. The edges of the front panel should also be drilled, as shown in Fig. 1, and the panel screwed into place.

This completes the bass section.

### Construction of treble horn

As in the concrete version the horn has flat top and bottom and curved sides. Fig. 2 gives details for the cutting of the sections. Taking the top and bottom pieces first each piece can be cut from a rectangle 10 x 12 in, and 12mm ply should be

used. Each six-sided piece of wood should be marked up as shown and the curves constructed. The areas shown shaded will lie outside the horn when it is finished.

The curved sides of the horn should be cut from a flexible plywood such as bending ply. The cutting should follow the dotted curve so that the side can be glued vertically along one of the curved lines drawn on the top or bottom panel. The joint should be made using an 'impact' adhesive as the wood will be under stress. The remaining flat panel can be matched up and similarly fixed in place.

**Throat section.** Cut a 3 1/2 in diameter hole in a 4 in square piece of 5mm ply (not shown in Fig. 2) and glue it in place over the throat end of the horn. Fill the inside of the throat region with Polyfilla (interior grade of course) the four 'fingers' of plaster stopping about 3 1/2 in from the throat. This procedure provides the correct exponential transition from circular to rectangular cross-section.

When the Polyfilla is dry give the inside of the horn a layer of undercoat and a couple of layers of gloss paint. The Eagle FR4 drive unit can be fitted to complete the treble horn.

### Crossover circuit

The modifications to the bass horn have reduced its efficiency. Advantage is taken of this in that the attenuating resistors in series with the FR4 are bypassed with a small capacitor to boost the top and compensate for the somewhat reduced efficiency of the horn at high frequencies. The series network is shown in Fig. 3.

**Winding the chokes.** A 2 in piece of 3/8 in diameter ferrite rod (with cardboard discs glued on at the ends) can be wound with 37ft 6in of 24 s.w.g. enamelled copper wire. The turns should be close and the

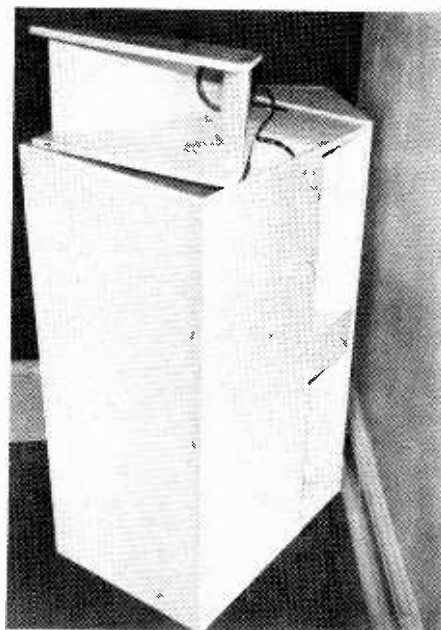

A finished speaker in its corner.

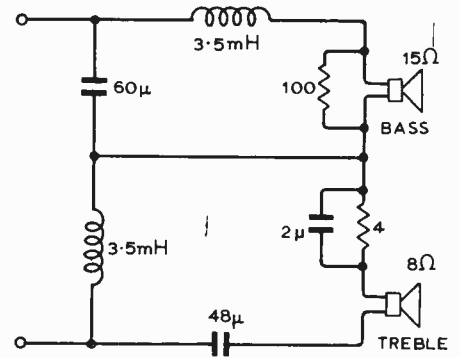

Fig. 3. Crossover circuit using a 1/2-section series network. Resistors can be 1/2W.

layers neat. The ferrite rod is available in 4 in and 6 in lengths from G. W. Smith (Radio) Ltd. To break the rod, first file a shallow notch. Place a pin on a hard surface, such as a metal ruler, and with the notch facing upwards press the ends of the rod downwards with the pin lying exactly below the notch. This should result in a clean break.

**Capacitors.** The reversible 50V electrolytic capacitors used are available from K.E.F. Electronics Ltd, of Tovil, Maidstone, Kent. 60µF capacitors are available but the 48µF required on the treble side is made up from 3 x 16µF units. The prices are 48p per pair for the 16µF, and 68p per pair for the 60µF units.

### Horn performance

The system described (which was demonstrated at the Audio Fair) will work perfectly if the bass horn is placed in the corner up against the two walls. However, a gap of up to four inches will result in no significant change in performance. The treble horn can be turned round to alter the apparent direction of the sound.

Because very few loudspeakers are capable of launching plane waves at mid-range frequencies few listeners ever hear really good stereo. It is a characteristic of a well-designed radial horn (and a well-designed flat electrostatic radiating element) that the pressure contours have flat fronts. The intersection of two such wavefronts, provided by loudspeakers angled in toward the listener, produces a stable stereophonic image. Constructors of a pair of horns for stereo reproduction will find that they can move freely about in their listening room in the same way that they can move about at a live recital.

Of course, the type of radiation pattern described is a *sine qua non* for worthwhile quadraphony.

Overall efficiency of the system is such that it is unlikely to be overdriven in domestic use, even at high sound levels, when used with a 10W-per-channel amplifier.

A provisional patent application has been filed on aspects of the system.

# The Poor Relation — TV Sound

by J. C. G. Gilbert, F.I.E.R.E.

The editorial in the October issue of *Wireless World* and the subsequent discussion evening held by the Royal Television Society once more highlighted the poor sound quality of the average television receiver.

One has always been impressed with the B.B.C.'s insistence on transmitting the highest sound quality compatible with existing conditions. When the B.B.C. started its 405-line television service there was no limitation on the audio bandwidth and for the first time one had the opportunity of designing equipment and loudspeakers capable of reproducing up to 15kHz. The early commercial television receivers had specially designed loudspeakers mounted in heavy consoles, and I well remember a particular H.M.V. receiver (with the picture tube mounted vertically and viewed from a mirror set at 45°) that had outstanding sound quality in 1938.

If one troubles to study the specifications of current television receivers one seldom finds a loudspeaker unit larger than 7 × 5in while the majority use loudspeakers about 5 × 3in and an audio power output of between 1 and 2 watts. Even in the large colour television consoles where space is available it is unusual to find more than one unit exceeding 8 × 5in, although one company does use two 8 × 5in units driven by a 3-watt amplifier.

But if one analyses all the loudspeaker units employed they are poor in quality by comparison with those even in unit audio systems which many of the leading television manufacturers now find of commercial interest. It is a strange fact of economics that the cost of a modern black-and-white large screen receiver is little different from the 1938 models. The complexity and sophistication of modern television receivers justifies a higher selling price compared with pre-war and early post-war models, and the higher selling price would allow for considerable improvements in the sound circuits, loudspeakers and acoustic treatment of the cabinets.

Whenever one discusses TV sound quality with the industry and asks why improvements are not made, one always hears a standard reply that they seldom receive complaints and the public would

either not be prepared to pay more or they are satisfied with current standards. The real problem lies with the manufacturers who have never given the public the opportunity of hearing the excellent sound that is transmitted, and the public believe that the sound they hear is the best that the broadcasters transmit.

With the upsurge in high-quality reproduction from gramophone records and magnetic tapes surely the public must wonder why the television sound does not compare with even average priced disc or tape reproducers. Until recently the British television manufacturers have had no overseas competition as no foreign manufacturer would produce a receiver for the unique British 405-line standard or for the later dual standard 405/625 system. With the coming of nation-wide coverage with u.h.f. transmitters operating on comparable standards to those in Europe, and in particular with the common PAL colour system, European and Japanese manufacturers are becoming very interested in the British market, and for the first time British television manufacturers are meeting foreign competition. Many of the European sets provide features unknown in British designs, such as tone controls, large loudspeakers, amplifiers up to 5 watts undistorted power output, and an external connection so that the television set can be used in conjunction with a high-quality sound system.

Almost invariably British television sets do not use an isolating transformer between the mains supply and the receiver circuits, and in spite of all the precautions taken against shock there has been the occasional fatality. While valves were the normal method of providing signal amplification, timebases, etc., the use of the a.c./d.c. chassis was partially justified on economic grounds, although the broadcasting authorities always insisted that receivers they purchased should have double-wound transformers, as does the Inner London Education Authority for the schools television service. Now that TV sets are wholly or partially transistorized, much cunning has been required to design the receiver still using the a.c./d.c. principle. One British manufacturer (Decca) is using a double-wound mains transformer in all new models and

will provide a low-level, low-impedance signal to connect to any high-quality amplifier system, and includes tone controls for the built-in amplifier.

In the laboratories at The Polytechnic of North London measurements were made on three single-standard British receivers. First, the internal loudspeaker was disconnected and replaced by a non-inductive resistive load of the same resistance. The output from a Bruel & Kjaer beat-frequency oscillator was connected to the input of the audio amplifier and the response curve plotted on the B & K automatic recorder. It appears obvious that to reduce 50Hz hum the low-frequency response has been attenuated drastically below 100Hz in each receiver. In the case of the Philips receiver high-frequency attenuation starts at 3kHz and is 12dB down at 10kHz, while both the Bush and Decca receivers fall by only 3dB at 10kHz. Some total harmonic distortion measurements were made with a Radiometer THD meter, and confirmed with a Marconi Instruments THD meter. The manufacturer's published specification of maximum power output was used as a reference level.

#### Total harmonic distortion (%) at 1kHz

	Bush	Decca	Philips
3.0W	—	12.5	—
2.0W	—	1.47	—
1.5W	5.75	1.47	13
1.0W	2.15	1.46	5.42
750mW	1.55	1.52	4.15
500mW	1.0	1.68	3.05
100mW	0.28	2.56	1.31
50mW	0.28	2.85	1.4

The opportunity occurred during these tests to check the overall distortion of the Bush receiver while the I.T.A. transmitter was radiating a 440-Hz tone, and this was measured to be 6.5% at a power output of 1 watt. The loudspeakers were reconnected and the acoustic performance curve was made in a large anechoic chamber and the accompanying curves illustrate the results. Two of the sets, Bush and Philips, show an attenuation of around 15dB at 100Hz and a rapidly falling curve above 3kHz being about 15dB down at 10kHz. The Decca set has a far less peaky curve which is badly attenuated only below 100Hz, but extends smoothly up to 10kHz. (While this receiver is designed mainly for educational use and gives higher than average vision and sound quality, it has been available to the public.)

While observing the sound performance of the Bush receiver during the I.T.A. transmission on an oscillograph the accompanying photograph was taken which reveals the line timebase frequency superimposed on the 440Hz tone. While the 15kHz line timebase frequency will not be audible to everyone, it may be the reason why severe attenuation is introduced into the audio circuits so that beat tones are reduced in amplitude.

There was a time when the major receiver manufacturers ignored the introduction of high-quality sound repro-



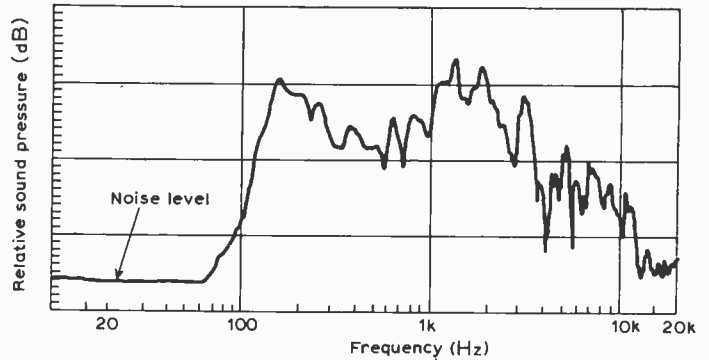
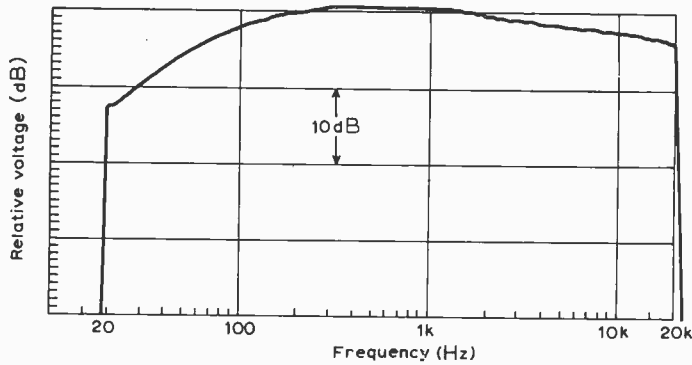

*Bush TV191S receiver. (left) Frequency response of audio amplifier; signal fed to grid of a.f. amplifier valve; output loaded with 3'. (right) Frequency response from loudspeaker with input signal as before; 1V r.m.s. across l.s. at 1kHz reference frequency. Microphone, B & K 4133 at 0.5m.*

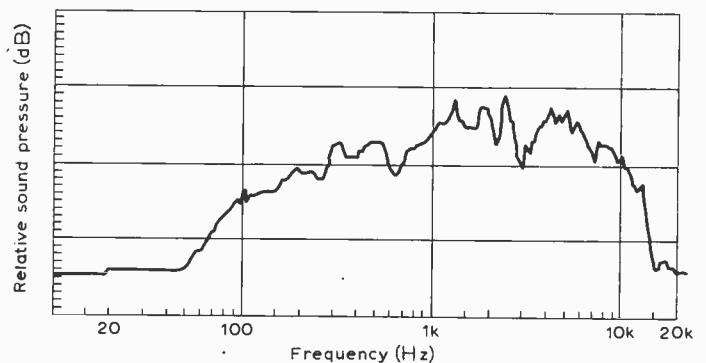
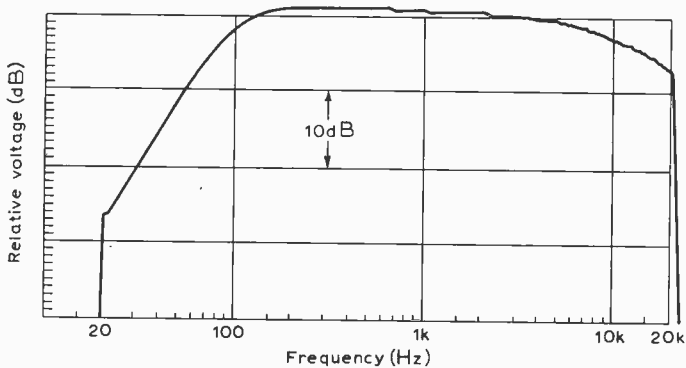

*Decca DPT receiver. (left) Frequency response of audio amplifier; signal fed across volume control; output loaded with 15Ω. (right) Frequency response from loudspeaker with input signal as before; 1V r.m.s. across l.s. at 1kHz. Mic. as above.*

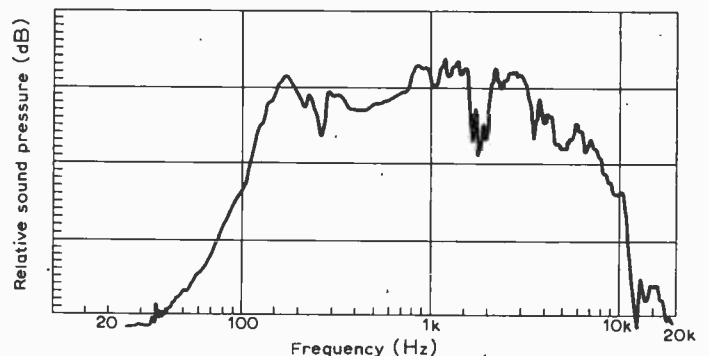
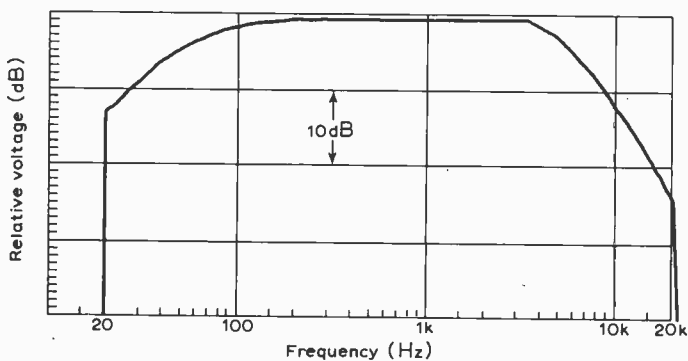

*Philips G23T212-02 receiver. (left) Frequency response of audio amplifier; signal fed to top of volume control and earth; output loaded with 35Ω. (right) Frequency response from loudspeaker with input signal as before; 1V r.m.s. across l.s. at 1kHz. Mic. as above.*

duction equipment by specialist firms such as Quad, Leak, Rogers, etc. The success of the series of Audio Fairs showed that a large section of the British public does appreciate a high standard of sound reproduction, and yet it is denied to them with television receivers. We can enjoy high quality B.B.C. mono and stereo transmissions on v.h.f., gramophone records and even cassette tapes, yet the sound quality of 95% of British television receivers is comparable only to a medium-wave portable radio receiver. Why cannot the manufacturers consider designing a range of receivers with alternative sound amplifier circuits and loudspeakers? One is told that 'cost effectiveness' (a phrase heard many times from the B.R.E.M.A. representatives during the R.T.S. discussion) is an important factor in receiver design, but now that plug-in

printed circuit boards are available, could one not have alternative quality and power capacity boards?

It seems an odd situation that one is forced to accept a low standard based not

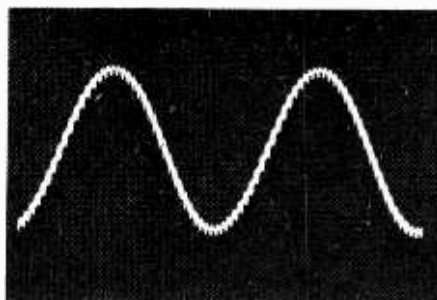

*Oscilloscope showing line timebase frequency on 440Hz test tone.*

on technical grounds, for British designers can produce the finest amplifier systems in the world, but because the manufacturers fear that if they raise the selling price by a few pounds, their sales will suffer. If one makes a comparison with the motor industry in 1938 one could buy a Standard 8 car for less than £125, while a comparable modern car costs at least £750. The 1938 television receiver cost around £80 and, although it is a great credit to the television manufacturers, the modern sophisticated set still costs around the same price.

The television programme producers go to great lengths to pick out solo passages, and how distressing it must be to them when they show a close-up shot of the tympanist or double basses and they know that all the viewer hears is a travesty of the real sound.

# Circuit Ideas

## Pulse generator for diode emitters

For engineers involved in the applications of gallium arsenide phosphide, red-light emitting diodes, or gallium arsenide, infra-red emitting diodes, an s.c.r. can offer a simple and inexpensive pulsed drive system. The relaxation oscillator circuit described will generate 1A short duration pulses at 10kHz, or with a larger capacitor in  $C_1$  position much higher pulsed currents can be produced — up to 10A — at lower pulse rates. The pulse current through the emitter diode may be monitored as the voltage across  $R_2$ . This resistor can be a potentiometer and used as a fine diode-current control.  $C_1$  will dictate the available pulse current as well as the pulse rate, in conjunction with  $R_1$ . If it is necessary to 'earth' the case or can of the emitter,  $R_2$  may be interchanged with the emitter diode and the positive rail may be connected to the earth or chassis.

The pulse duration for half amplitude pulse width with the values shown, is  $1\mu s$  and its rise time is less than  $0.5\mu s$ .

The circuit component values are for the 2N2323 and 2N2324 devices, however the

circuit will function with other thyristors; for example the economical 2N5060 and 2N4144 series. The use of alternatives may require the adjustment of  $R_1$  between  $470\Omega$  and  $2.2k\Omega$  — if necessary  $C_1$  should be changed to obtain the desired operating frequency. The  $C_1$  capacitor should be of

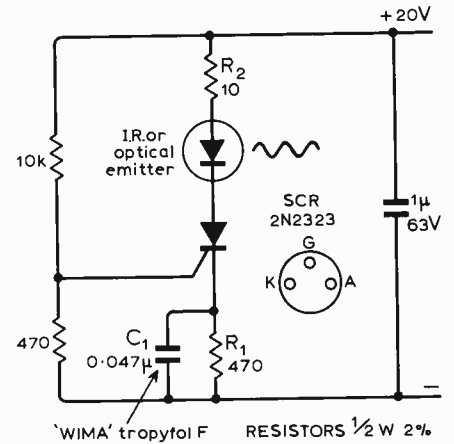

the type specified or polystyrene.

For efficient detection of the pulsed visual or infra-red output, the Plessey SC1, or Ferranti MS9 solar cells will give good results at short range without lenses or other optical aids.

D. M. BUSSELL,  
Bristol.

## Matching unit for tuners and i.f. strips

When experimenting with tuners and i.f. strips where the tuner may be commercial and the i.f. strip home made, or where the tuner uses p-n-p transistors and the i.f. strip uses n-p-n transistors, a special difficulty arises in connecting the two units

together. That is, the difficulty in connecting the a.g.c. (a.f.c.) output of the i.f. strip to the a.g.c. (a.f.c.) input of the tuner. The tuner may require an a.g.c. voltage of opposite polarity to that available from the i.f. strip. Furthermore the tuner may require the a.g.c. voltage to have a certain off-set value, i.e. a given a.g.c. voltage at zero input signal. If the a.g.c. voltage is  $y_1 = m_1x + c_1$  (to a first approximation) where  $x$  = signal strength in dB and  $c_1$  = a constant, we need  $y_2 = m_2x + c_2$  for the tuner. The unit shown below performs this

function.  $IC_1$  adds a constant  $-c_1$  to  $y_1$ . Also the gain of  $IC_1$  can be changed by changing the feedback resistor with  $S_2$ . Thus the output of  $IC_1$  is  $m_2x$  times  $-1$ .  $IC_2$  can be switched in or out with  $S_1$  to select the polarity required.  $IC_3$  is therefore  $y_2 = \pm m_2x + c_2$ . Setting up is quite simple. With no signal input to the tuner rotate  $R_1$  for a null reading on  $M_1$ . Select the required gain with  $S_2$  and use  $R_2$  to give the required output with no input.  $S_3$  selects the f.s.d. of  $M_1$ .

ALAN CLEMENTS,  
Warrington,  
Lancs.

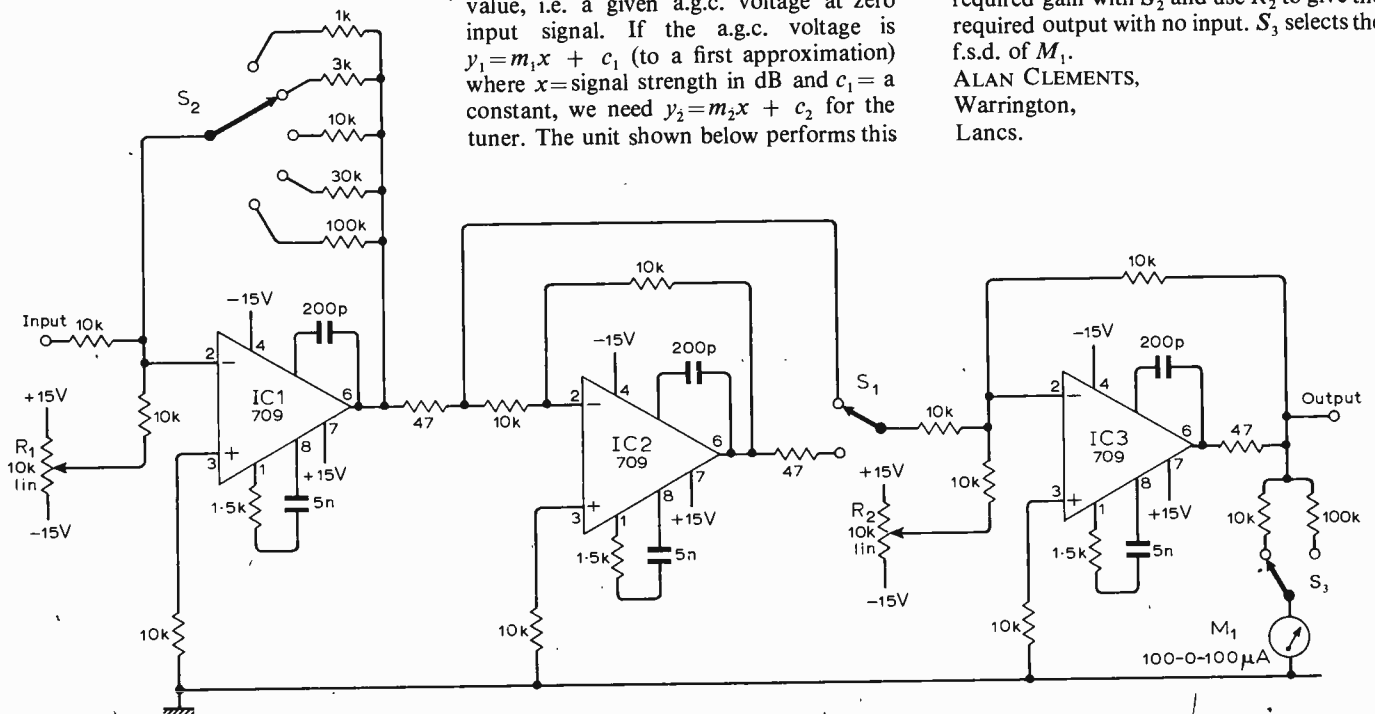

# Dual-trace Oscilloscope Unit

## 6. Final details and construction

by *W. T. Cocking\**, F.I.E.E.

The development of this instrument has been described in the previous five articles, and the various circuit diagrams given here fully describe the final model. The purpose of the unit is to enable two different signals of the same frequency to appear simultaneously on the screen of a cathode-ray oscilloscope. There are two separate signal channels, the outputs of which are combined, and an electronic switch renders the channels alternately operative.

At full gain, the overall gain is unity, but each channel has its own gain control and input attenuators so that signals of differing amplitudes can produce the same size traces on the screen. The chief practical use of a dual-trace oscilloscope is to enable the relative timing of events in the waveforms of voltages at two different points of a circuit to be compared. In the case of a multivibrator, for example, the waveforms of a synchronizing signal and the output signal can be observed simultaneously. This is often a great help in obtaining proper operation.

Each signal channel has an input probe which is connected to the unit by 3ft of coaxial cable and which attenuates the signal to 1/10 of its input value. At the same time it reduces the total capacitance of cable and amplifiers, which is effective at the input of the probe, to 1/10 of its actual value. The probe input capacitance is about 12pF and the resistance 1MΩ. The amplifier has a maximum gain of 10 times to make up for the probe loss and an input resistance very large compared with 0.1MΩ.

Two attenuator sections, one of 3:1 ratio and the other of 10:1 ratio are provided, and either or both in cascade can be connected between the probe and the amplifier, while the gain control has a minimum range of 3.33:1 to fill the gaps in the attenuators. The amplifier is intended for a maximum output of 1V peak-to-peak, but will actually provide about 2V without appreciable distortion. In normal usage, it is intended to give only 0.5V because two separated traces of this amplitude give the 1V which it is assumed will fill the c.r.o. screen. In any case, the shift voltage needed to separate the traces is itself equivalent to a 0.5V signal, so provision must be made for the output stage to handle it.

All told, there are two probes, two × 3

and two × 10 attenuator sections, and two amplifiers. All these are identical, save for one or two minor details in the amplifiers. The circuit diagrams show only one channel and the details of difference are noted on them. The electronic switch comprises a bistable which drives switching transistors in the amplifiers and is itself triggered in alternative ways. It can be triggered by a sawtooth from the oscilloscope itself if one is available. This is the better method if it can be used, except at low and high signal frequencies. On the one hand excessive flicker and on the other poor bistable triggering may render it unsatisfactory. To cover these conditions and, also, to enable switching to take place when the c.r.o. cannot provide a sawtooth output, an internal sawtooth generator is provided having three switched frequency ranges and a continuous control of frequency.

Additionally, a small signal amplifier is

provided for one channel only so that the signal from one channel can be fed to the c.r.o. for triggering its timebase. It is essential that the oscilloscope be provided with arrangements for synchronization by an external signal. Internal synchronization cannot be used.

A general block diagram of the unit is shown in Fig. 1. As well as illustrating the functioning, this shows the unit interconnections. Constructionally, the four attenuator sections form a sub-unit, everything but the switches being mounted in four screened compartments. The switches and the input coaxial sockets are mounted on the front panel and fall within the screened compartments when these are attached to the front panel. The amplifier boards A and B, the back panel, the switching waveform generator (board C) and the decoupling form a second sub-unit attached to the front panel behind the panel controls and alongside the

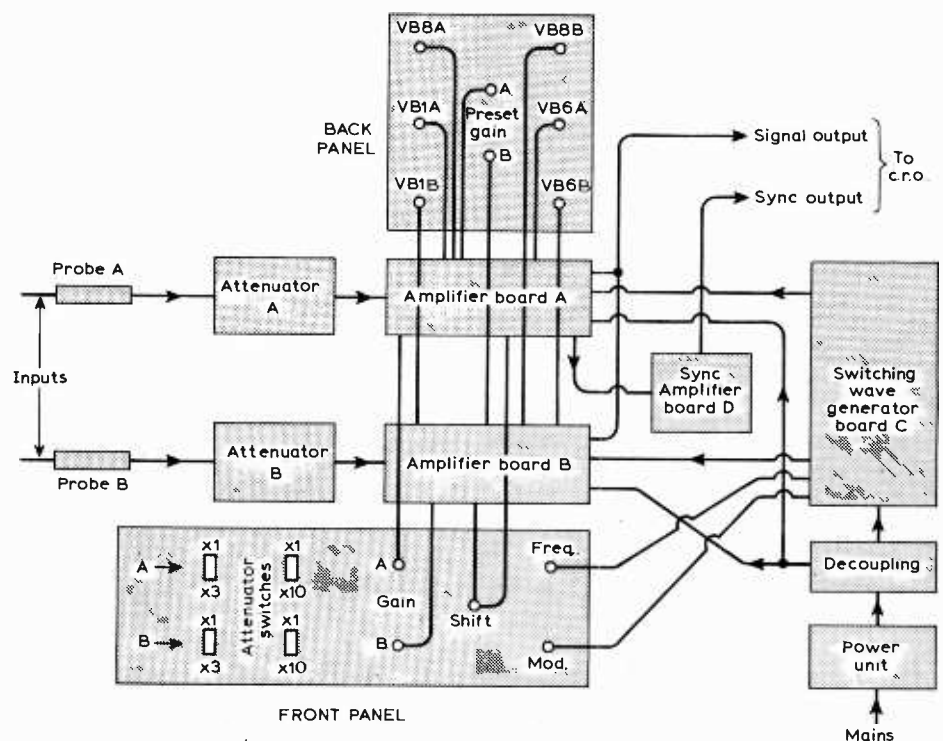

Fig. 1. Block diagrams of the equipment. The attenuators A and B form one sub-unit and Boards A, B and C together with the back panel and the decoupling form a second sub-unit. Both sub-units and the sync amplifier Board D are mounted as the front panel. The power supply is on the back of the case.

attenuator unit. The power supply components are mounted on the, detachable, rear of the case, and the sync signal amplifier is mounted on the front panel, the sync output socket terminal actually projecting through a hole in the board.

Unless the case is to be specially made for the job, one normally has to start the mechanical design by choosing a suitable standard case. The case then has a large influence on the mechanical design. We chose the Olsen 26B which measures  $8\frac{3}{4}$ in wide by  $5\frac{1}{2}$ in high by  $8\frac{1}{4}$ in deep. Its volume is ample, but the front panel opening (not the panel itself) is only  $4\frac{7}{8}$ in by  $7\frac{1}{4}$ in. This is definitely on the small side. Another  $\frac{1}{2}$ in in height and  $1\frac{1}{2}$  to 2in in width would be an improvement. Boards A, B, and C could then be longer and decoupling components could be mounted on them, instead of separately. We should arrange this if we were to make a second model.

The front panel carries five coaxial sockets; two are for the connection of the two input probes, one is for the signal output to the oscilloscope, one for sync output to the 'external sync' terminal of the oscilloscope and one for the sawtooth output from the oscilloscope. There are nine controls mounted directly on the front panel. Four of them are switches for the input attenuators, two for each channel. These are Radio Spares slide d.p.d.t. switches. There are four potentiometers; two are gain controls, one is the shift control and one the switching frequency control. Finally, there is a 4-way 3-pole rotary switch which controls the switching mode and frequency. One position gives switch triggering from the oscilloscope timebase, the other three positions give triggering from the internal sawtooth generator in three frequency ranges.

Two sub-units, the attenuator unit and the amplifier and switching unit, are also mounted on the front panel.

Fig. 2 shows the circuit diagram of the probe and attenuators of one signal channel. Everything in Fig. 2 is, of course, duplicated for the second channel. Throughout we shall designate one channel as A and the

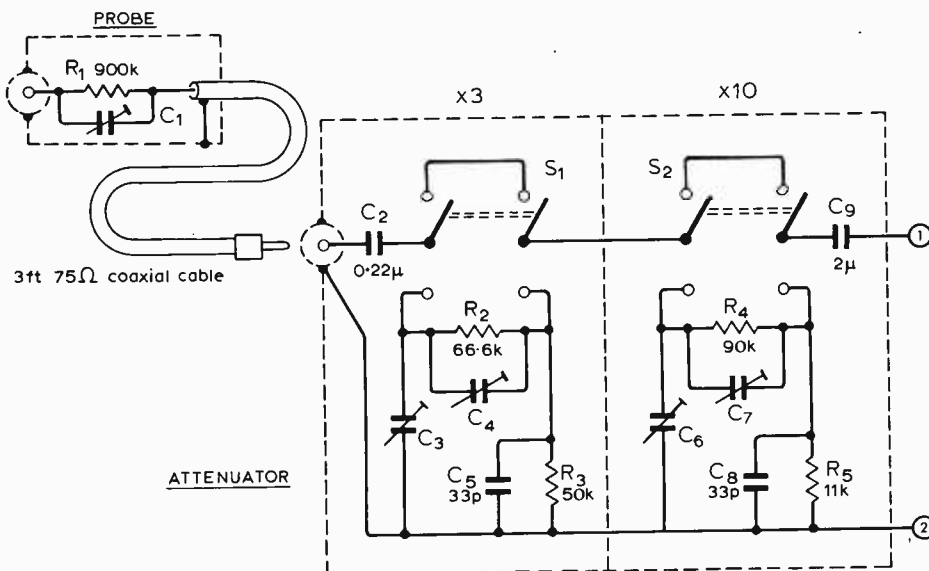

Fig. 2. Circuit diagram of the probe and attenuators for one channel. All resistors must be  $\pm 1\%$ .

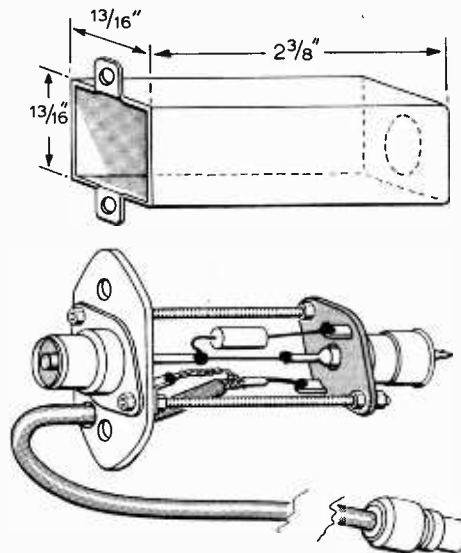

Fig. 3. Constructional details of a probe are given here.

other as B, and we shall append these letters to component references when it is necessary to distinguish between similar components in the two channels. Thus, if we want to refer to  $S_{1A}$  of channel A specifically, we shall call it  $S_{1A}$ , whereas if the reference to this switch applies to either channel we shall call it  $S_1$  only.

All the resistors used in the probes and attenuators should have the values shown with a tolerance of  $\pm 1\%$ . As the values required are not preferred ones, they are obtained by using pairs of resistors in parallel; two of  $1.8M\Omega$  for  $900k\Omega$ , two of  $180k\Omega$  for  $90k\Omega$ , two of  $100k\Omega$  for  $50k\Omega$  and two of  $22k\Omega$  for  $11k\Omega$ . For the  $66.6k\Omega$  resistors one may find low tolerance  $68k\Omega$  resistors which have this value; otherwise, it is best obtained from  $120k\Omega$  shunted by  $150k\Omega$ . The trimmers are all Philips concentric types of  $30pF$  maximum capacitance; they are supplied fitted to a small diamond shaped Paxolin mounting board. The input coupling capacitors  $C_2$  are of

$350V$  rating, the output ones ( $C_9$ ) can have a much lower rating,  $100V$  is ample.

### Probes

Each probe requires a 3ft length of  $75\Omega$  coaxial cable (television aerial feeder type is suitable), a coaxial plug and socket, a Philips trimmer, a  $900k\Omega$  resistor or equivalent, an Aladdin screening can  $2\frac{3}{8}$ in by  $\frac{3}{4}$ in square (Home Radio CR17), some 6BA studding, nuts and a small piece of about  $\frac{1}{16}$ in aluminium sheet. The construction are given in Fig. 3. A piece of aluminium about  $\frac{13}{16}$ in  $\times$   $1\frac{1}{2}$ in is drilled to suit the can mounting lugs and then filed to fit the can at the sides and to have rounded ends. Holes for the coaxial socket are drilled. We used the Belling-Lee L604/S socket (Home Radio PK40) and with this the mounting screws and nuts will just fit into the diagonally opposite corners of the can, albeit rather tightly. Short lengths of studding are used for mounting and these carry the trimmer.

The trimmer mounting board is too large to go in the can and the hole spacing is too wide to match the stud spacing, since this is fixed by the coaxial socket. The holes must, therefore, be drawn with a round file until the trimmer will fit on the studs. It is then fixed by nuts and the surplus material filed away. This requires care because it will turn the holes into open-ended slots and it is quite easy to break the mounting board.

The trimmer is mounted so that its centre connection is about  $\frac{1}{8}$ in away from the centre socket connection and the two joined by a piece of wire. A hole to take the cable with a tight fit is drilled through the aluminium base plate and there is just room for this between the flange of the coaxial socket and the corner of the can. A solder tag under the adjacent nut of one of the studs gives the earth connection for the cable braid. The cable inner is soldered to the short outside tag of the trimmer. The resistors are soldered to the long tag and to the coaxial socket centre. The hole at the top of the can must be enlarged to take an insulated trimming tool. We made it  $\frac{3}{8}$ in diameter.

The general form of the attenuator unit is sketched in Fig. 4. This was constructed from sheet tinfoil. A piece  $4\frac{1}{2}$ in wide is bent as shown to form an open-ended box with mounting flanges; it is  $3\frac{1}{2}$ in deep and  $2\frac{1}{2}$ in wide. This mounts on the front panel by four screws in the flanges. Before mounting, however, a horizontal tray is fitted to divide it into two equal compartments, one for channel A and the other for channel B. This is a piece of tinfoil with flanges turned down at the sides and back. It is mounted by 8BA screws and nuts or small self-tapping screws.

The two compartments so formed are each divided into two by vertical pieces of tinfoil. They are mounted to the back and to the horizontal shelf by screws through flanges. The same screws mount both on the shelf and so the flanges on the two must be bent in opposite ways. The fronts are not fixed and are cut to clear the front panel by a small amount and slots are placed for the interconnecting wires. Covers at top and bottom are not needed. When the assembly is mounted in the panel, the coaxial input sockets come inside the input section boxes

and, of course, there is one switch in each compartment.

Four holes are placed in the output side, for the 'hot' and earthy leads from the output compartments to the amplifiers, so that they come close to the connecting points in the amplifier boards. Six lengths of 6BA studding pass through the horizontal shelf, so that in each of the four compartments there are three lengths available. On each of these three two Philips trimmers are mounted. The middle stud is common to two trimmers. Each outer stud also carries a small tag-board having three tags. All the capacitors and resistors are carried between the two tag-boards in each compartment.

Leads, which should be sleeved where necessary, are attached to the trimmers before they are mounted and connected to the appropriate tags when they are mounted. The input  $C_2$  and output  $C_3$  capacitors must be fitted before the unit is fixed to the panel because they lie underneath the tag strips. The switches must be wired before mounting the unit to the panel and an insulated earth wire should be placed in position to pass between the compartments as the unit is placed into position. Connections to the appropriate tags can then readily be made. The resistors and small capacitors can be added *in situ*.

The output connections are leads which are soldered to the amplifier input points before the amplifier unit is mounted. When this is being fitted, the leads are passed through the holes in the side of the attenuator unit and worked through as the unit is brought into position.

The switches are connected so that in all cases the upper position is one of zero attenuation. This means that all switch connections are the same when regarding them simultaneously from the rear. With respect to the actual attenuator assemblies, however, those for channels A and B are inverted. It is actually the attenuator assemblies which are inverted, but in working on the

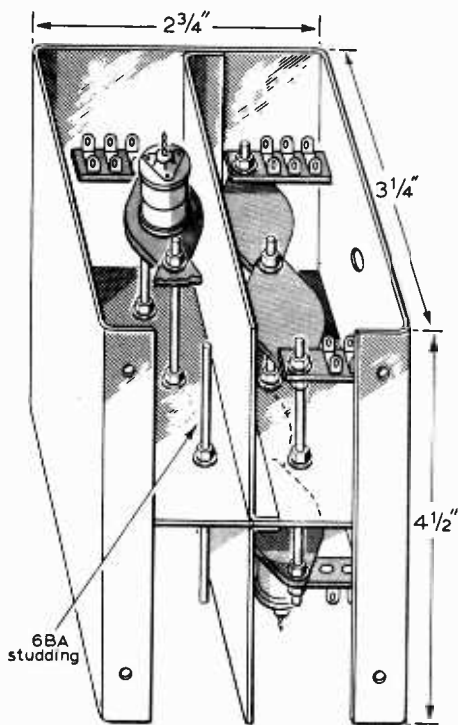

Fig. 4. Details of the attenuator sub-unit.

assembly one tends to think in terms of the attenuators rather than of the switch. Care must be taken over the connections.

**Amplifiers**

The circuit diagram of the channel A amplifier is shown in Fig. 5. All parts between the numbered points 1-4 on the left and 6-14 on the right one mounted on Veroboard. Some of the potentiometers shown externally and the gain controls are mounted on the front panel, some on a back panel. The board for channel B is identical except that connection point 5 is not provided and the 330Ω resistor  $R_{C8}$  is not fitted.

As explained in an earlier article, resistors

immediately associated with a transistor are not numbered on the diagram. They are referred to as  $R_B$ ,  $R_C$  or  $R_E$  as appropriate with the number of the transistor appended. Resistors which cannot be so identified are numbered in the usual way, starting afresh for each diagram. The diagram is drawn approximately in the way the parts are laid out on the Veroboard.

Each amplifier is built on a piece of Veroboard having a 0.15in matrix of holes. The board is the usual 16 holes wide and is 28 holes long. Only 14 of the 16 copper strips are actually used for connections. A hole near each corner is enlarged to 6BA clearance. The two boards are screwed together with their copper sides facing, and 1/4in apart, by 6BA screens and nuts. Thus, one board is upside down compared with the other.

With the two boards so screwed together, there are still four corner holes, two in each board, by which the pair are mounted to the front panel by four 3 3/4in lengths of 6BA studding. The front surface of Board A (top) is 1 1/8in behind the front panel and 1 3/4in behind it is a back panel which carries eight pre-set potentiometers.

Except for the pre-set gain controls, which must be moulded track types, they are all wire-wound (Radio spares or Egen). These are physically large but are not expensive. Miniature types for printed-circuit board are either much too costly or are unsatisfactory for this purpose. The back panel is merely a sheet of aluminium 4 1/4in wide by 4 3/4in high. It also carries in the centre a small tag strip for the two decoupling resistors, the two 500μF decoupling capacitors being held by clips at top and bottom.

Details of the circuit boards are not given because of the difficulty of producing clearly legible drawings free from errors.

The BC107 transistors have their leads arranged as shown in Fig. 6. By bending the leads slightly they can fit into three holes in a common column, usually holes in adjacent rows, but sometimes it is

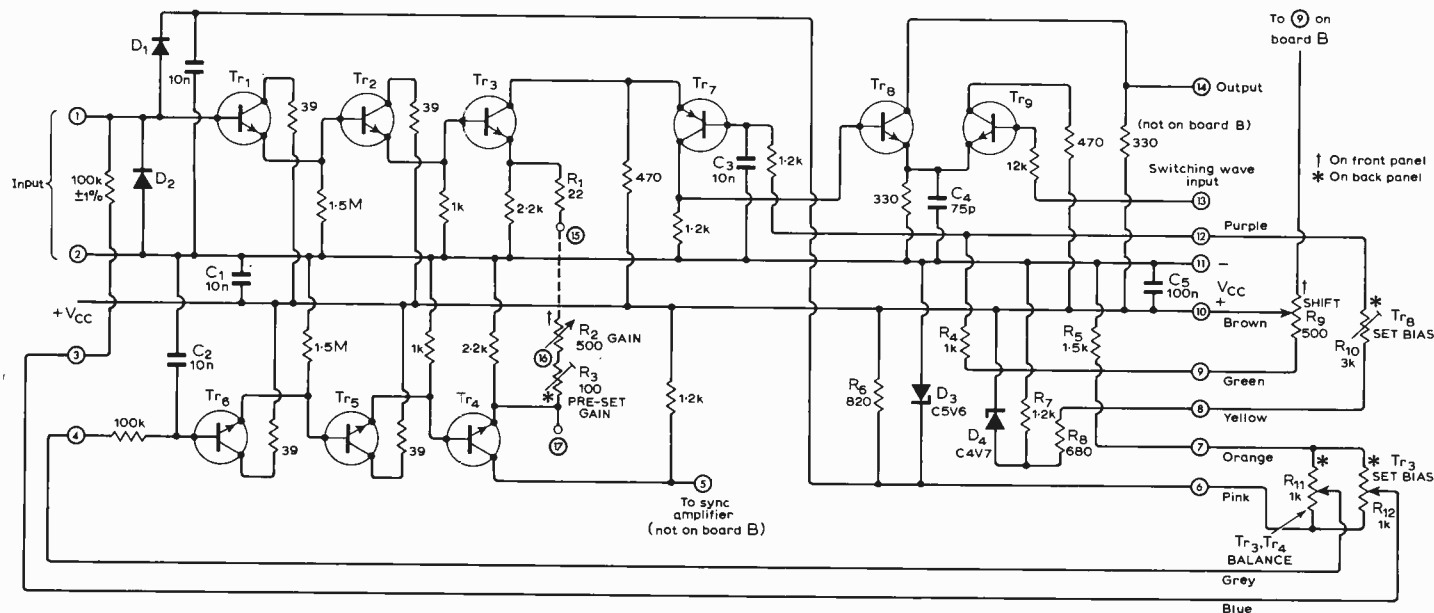

Fig. 5. Circuit of Channel A amplifier showing the external connections to the bias controls. Channel B is identical except that there is no 330Ω collector resistor for  $Tr_{8B}$  nor an output to the sync amplifier. The outputs of the two boards are joined directly together and the one resistor shown here is common to both  $Tr_{8A}$  and  $Tr_{8B}$ . All n-p-n transistors are BC107 and p-n-p are BC157.

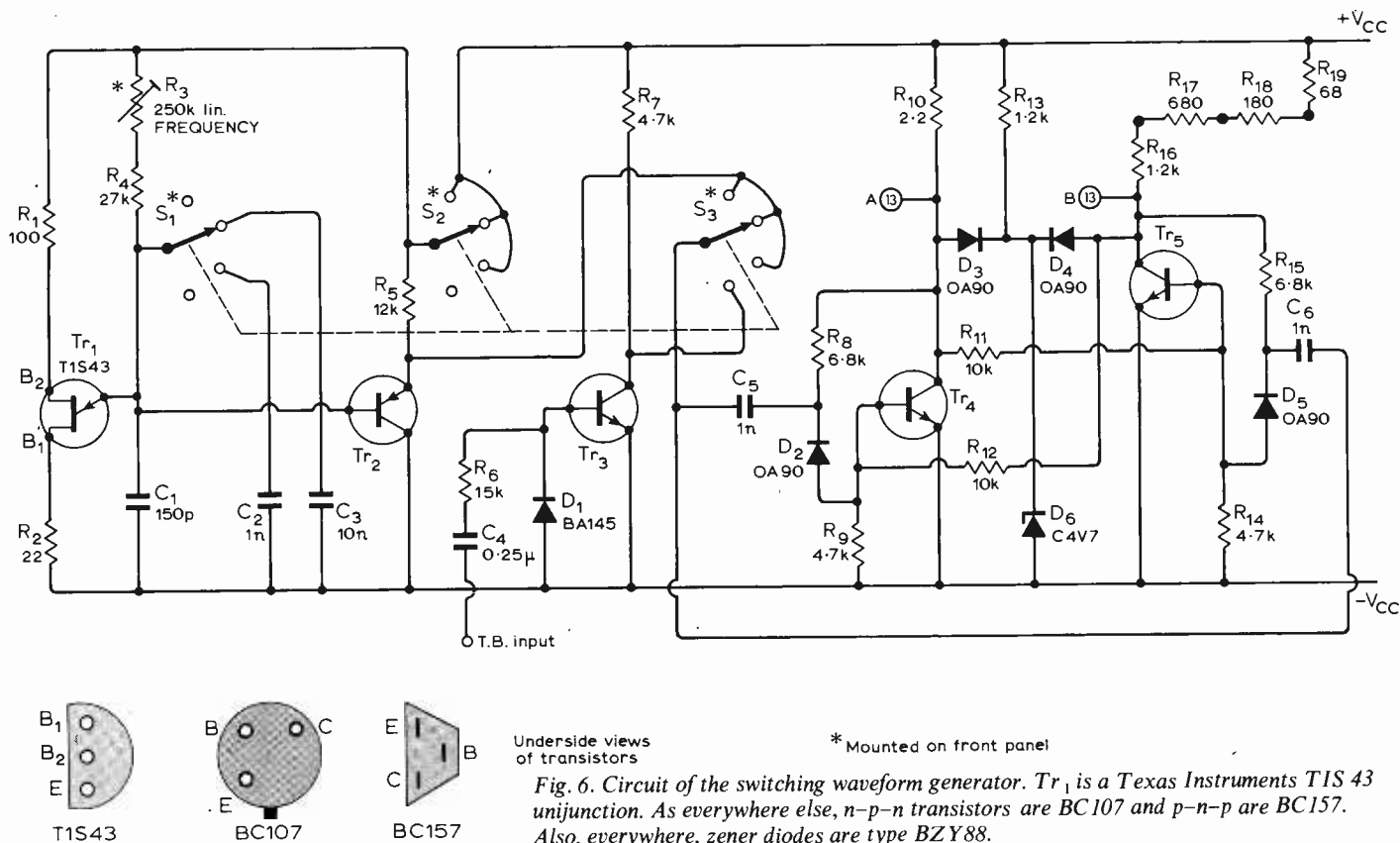

Fig. 6. Circuit of the switching waveform generator. Tr<sub>1</sub> is a Texas Instruments TIS 43 unijunction. As everywhere else, n-p-n transistors are BC107 and p-n-p are BC157. Also, everywhere, zener diodes are type BZY88.

desirable to spread the leads over four holes. The lead order is always E, B, C. In boards A and B, Tr<sub>1</sub>, Tr<sub>2</sub> and Tr<sub>3</sub> all use three adjacent holes and each transistor is staggered one row up on its predecessor, so that the emitter lead of the first is on the same strip as the base of the second, and the emitter of the second on the same strip as the base of the third. The emitter connections are all towards the top of the board. In Tr<sub>4</sub>, Tr<sub>5</sub> and Tr<sub>6</sub> the same arrangement is used, but now the emitters are towards the bottom of the board and the stagger is the opposite way. The layout of this second group is thus inverted compared with the first.

The BC157 transistors are of the lock-fit type and do not fit the holes in the Veroboard. We overcame this by soldering short leads of tinned copper wire to them and then treating them as wire-ended types. All told there are 20 type BC107, four type BC157 and one TIS43. We found that if one orders a quantity of BC107 they are quite likely to be supplied as a mixture of different makes. This becomes obvious through small differences in the case and lead-out wires. Sometimes, too, their designations may have a final letter A, B, or C. This letter indicates a range of h<sub>FE</sub>, those with A having the lowest range and those with C the highest. This does not matter because the circuit was designed to accommodate the full range.

Nevertheless, if the transistors are so designated, advantage should be taken of it by using pairs of the same grading in the corresponding stages of the differential amplifier. Thus, if one has a mixture of A, B and C grades, makes Tr<sub>1</sub> and Tr<sub>6</sub> the same grade, Tr<sub>2</sub> and Tr<sub>5</sub> the same and Tr<sub>3</sub> and Tr<sub>4</sub> the same, but it does not matter at all if Tr<sub>1</sub>, Tr<sub>2</sub> and Tr<sub>3</sub> are all the same. Similarly, if they are of different makes,

make corresponding pairs of the same make.

When mounting components, make a fair sized loop in the leads of R<sub>E3</sub>, R<sub>E4</sub> and R<sub>C7</sub> at the transistor ends. These three are all towards the outsides of the boards, and the loops enable a voltmeter to be more readily connected for setting up. On both boards, R<sub>E3</sub> and R<sub>C7</sub> are readily accessible; R<sub>4</sub> is less so for on both boards it comes towards the middle of the assembly, but can be reached with a long probe.

The pre-set and main gain controls are on opposite sides of the board and require one interconnecting lead which passes through an enlarged hole towards the centre of the board. Because of the reversal of one board with respect to the other it is convenient in wiring to reverse the order of connection of R<sub>2</sub> and R<sub>3</sub> in one channel compared with the other. This has no effect on performance. Note again that all four gain controls must be moulded-track types, not wire-wound.

It is advisable to check the operation of the boards independently before mounting them, for a good deal of dismantling is needed to get at anything when they are in

situ. Long leads for the controls do not matter and a temporary gain control can be rigged up. The input lead must be short if serious hum pick-up is not to occur. The most probable constructional fault is the omission of one or more breaks in the copper strip and the second is a piece of solder shorting adjacent strips. Apart from up-setting the operation, either fault may destroy a transistor or diode. When we made the first board we had no such faults. When we made the second we had several! Making a duplicate is less interesting and one tends to be careless! When testing Board B in this way, do not forget to add R<sub>C8</sub> (330Ω), the resistor common to both Tr<sub>8</sub>, but included in Board A only.

Before finally fitting the boards little cardboard boxes must be made to cover Tr<sub>1</sub>-Tr<sub>6</sub>. An ordinary filing folder is suitable material, and is cut so that when the sides are bent over it forms a box 1 3/8 x 2 1/2 in x 5/8 in deep. A strip of Sellotape around the outside holds the sides in place. The long sides go across the board, leaving R<sub>B1</sub>, R<sub>B6</sub> and C<sub>2</sub> outside on one side and R<sub>E2</sub>, R<sub>2</sub>, R<sub>E4</sub> outside on the other. It is held in place by a strip of Sellotape turned over the sides of the board. As explained in Part 5, these boxes are needed to reduce the effect of draughts on the differential stage when the unit is operated outside its case during adjustment.

Fig. 6 shows the circuit of the switching waveform generator, and everything shown there is mounted on Veroboard of the same size as used for Boards A and B. Transistor Tr<sub>1</sub> is a unijunction which generates a positive-going sawtooth of about 8V amplitude. Frequency is controlled in three steps by S<sub>1</sub>, and finally by R<sub>3</sub>, which is a panel control. The output is fed to the bistable Tr<sub>4</sub> and Tr<sub>5</sub> via an emitter follower

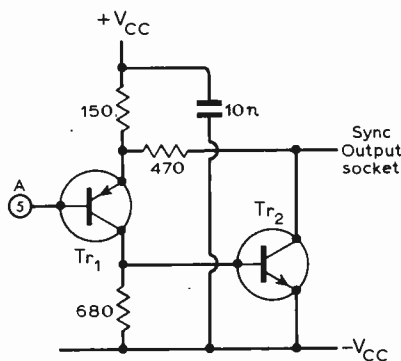
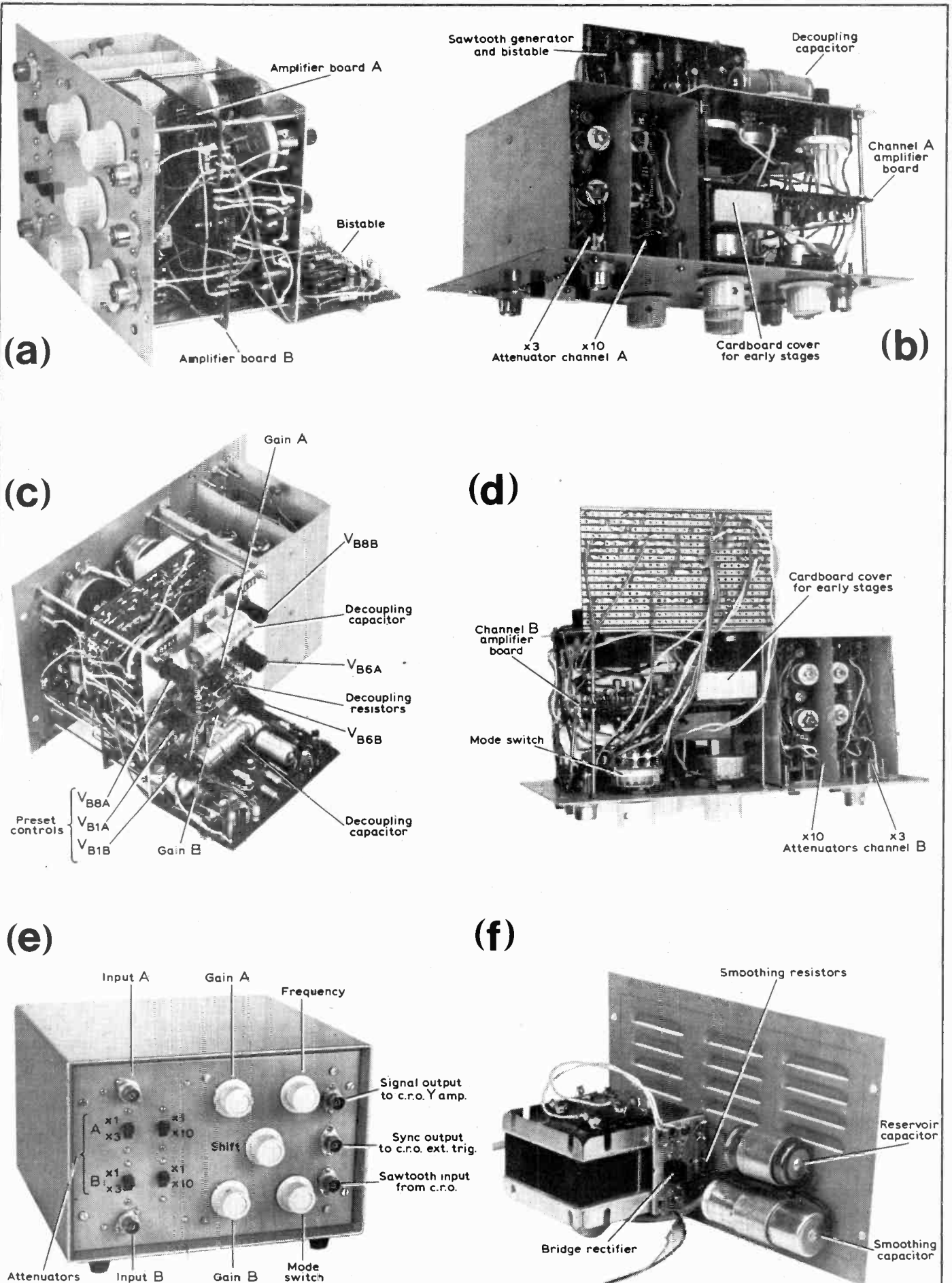

Fig. 7. Circuit of sync amplifier.



(a) End view showing how the amplifier boards are mounted. (b) General view of the top showing the channel A attenuators and amplifier board. (c) Rear view showing the sawtooth generator and bistable board, also the pre-set controls and decoupling components. (d) Underside view showing the channel B attenuators and amplifier board. (e) The complete instrument. (f) The power supply components are mounted on the back of the case. The transformer used is actually unnecessarily large.

$Tr_2$ , for which a p-n-p transistor is used.

To trigger the bistable from the oscilloscope timebase,  $S_2$  cuts off  $V_{cc}$  from  $Tr_1$  and  $Tr_2$  thus rendering the internal sawtooth generator inoperative, and  $S_3$  changes over the trigger connections. When the sawtooth output from the oscilloscope is negative-going the circuit shown is applicable and the values are correct for an amplitude of about 8V. For a larger amplitude  $R_6$  should be increased, for a smaller it should be reduced. If the oscilloscope sawtooth output is positive-going, the phase-reversing stage is not needed. In view of the smallish capacitance of  $C_5$  and  $C_6$ , the diode  $D_1$  is hardly needed, and so this stage can be replaced by a potential divider to give about 8V amplitude at  $C_5$  and  $C_6$ .

The sync-signal amplifier is shown in Fig. 7 and is constructed on its own small piece of Veroboard. It is mounted on the (long) fixed screws of the sync output coaxial socket with a hole between them to clear the centre spigot of this socket. A solder tag under one of the screws forms the common  $-V_{cc}$  point of connection for all boards. For boards A and B it is a length of No. 16 gauge tinned copper wire bent into a rough U and soldered to this tag at the middle.

Details of the power supply and decoupling are shown in Fig. 8. Since various makes of mains transformers may be used, the tolerance on output voltage may be abnormally great. At normal supply voltage there should be 12V on the Boards A and B supply and if it differs it may be adjusted by changing  $R_1$ . But if this is under 33Ω the smoothing may suffer. The tolerance of  $\pm 1.5V$  on  $V_{cc}$  is intended mainly to cover supply voltage variations and on setting up with a normal supply voltage,  $V_{cc}$  should be kept within 11.5-12.5V by adjustment of transformer tappings and/or the value of the smoothing resistor.

Before assembly all components should be checked. It saves time in the end. An ohmmeter test on transistors and diodes is normally sufficient to weed out faulty specimens. With most transistors the forward resistance is 1kΩ to 2kΩ and the back resistance infinite on the usual ohms range. Similarly for diodes, but the forward resistance of some types is no more than 500Ω.

Faulty specimens will usually show a short circuit, or near short-circuit, in both directions or else show infinity in both directions, depending on whether a junction has gone short-circuit or open-circuit.

The unijunction transistor tests as a resistance between  $B_1$  and  $B_2$  of the order of a few kΩ, but as a junction between E and emitter  $B_1$  or  $B_2$ .

If a semiconductor breaks down when wired into circuit, it is less easy to detect because the circuit resistances tend to obscure the ohmmeter tests. This is severe in Boards A and B because of the low value resistances. In Board C they are higher and useful ohmmeter tests can be made. Table 1 gives the reading obtained with everything connected normally, but disconnected from the power supply unit. There is sufficient difference between normal and reversed ohmmeter lead readings to give fair certainty of detecting a faulty transistor.

The frequency response of both ampli-

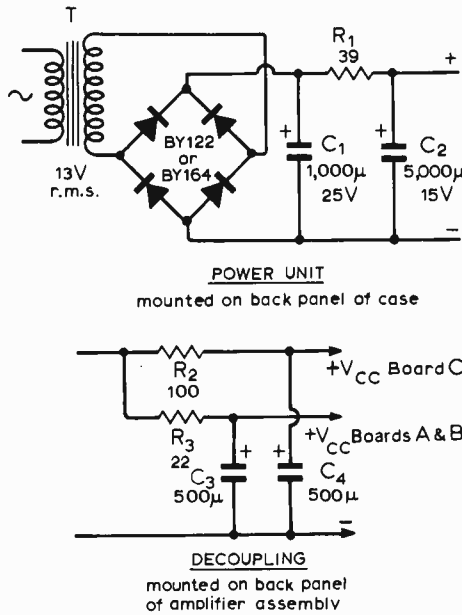

Fig. 8. Power supply and decoupling circuits. The former are mounted on the back of the case, the latter on the back panel of the amplifier sub-unit.

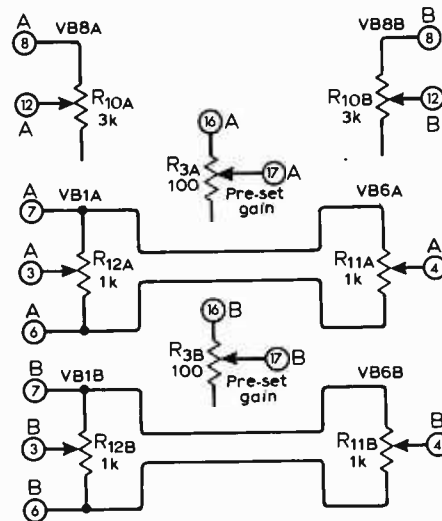

Fig. 9. Connections for the pre-set potentiometers on the back panels. Although not shown, the decoupling components of Fig. 9 are also mounted on this panel on the knob side, the resistors being on a tag board between the gain controls and the capacitors being held in clips above and below the controls.

fiers was measured by applying a sinewave input of 50mV r.m.s. to the amplifiers (no probes). This is 141.4mV peak-to-peak. The output was measured as 1.5V peak-to-peak on the oscilloscope, making the gain 10.6 times. However, these figures are subject to the errors of the valve voltmeter and oscilloscope and as 50mV is the smallest voltage readable with the meter used, it is likely that the accuracy is poor. This is for voltage amplification. In measuring the frequency response, the calibration accuracy of the voltmeter does not affect matters; it is the reading and resetting accuracy which count.

### Measurements on Board C Avometer on Ohms Range

Other lead on	Negative meter lead on $-V_{cc}$ (kΩ)	Positive meter lead on $-V_{cc}$ (kΩ)
$D_1$ cathode	0.86	1.4
$D_2$ cathode	3.1	8.5
$D_3$ cathode	3.1	8.5
$D_4$ cathode	1.2	2
$Tr_4$ base	3.4	1.3
$Tr_5$ base	3.4	1.3
$D_3$ anode	2	1.45
$D_4$ anode	1.8	1.5
$Tr_1$ emitter	1.5	2.8
$Tr_2$	20 kΩ meter + to emitter - to base 1.5 kΩ meter - to emitter + to base	

The response started to fall at about 3MHz, being  $-0.34dB$  for one amplifier and  $-0.58dB$  for the other. At 5MHz the figures were  $-1.7dB$  and  $-1.58dB$ , while at 10MHz they were  $-2.76dB$  and  $-3.72dB$  respectively. These are for the amplifier alone and are obtained by deducting the oscilloscope response from the measured figures; at 10MHz this was  $-1.2dB$ .

With the probes, the input was increased to 120mV r.m.s. and the output reduced to 320mV, the overall gain of A channel then being 0.94 while the B channel was unity. The probes had been aligned on square waves in the manner described later and the frequency response was only slightly changed. It became  $-5.66dB$  for channel A and  $-5.6dB$  for channel B. The two channels are thus very closely alike and there is no doubt about this because the actual values of voltage measurement on the oscilloscope were always near each other and so subject to the same calibration errors. Measurement accuracy is less for the actual drop in response at high frequencies, because at  $-6dB$  one voltage is only a half of the others.

In any case, the 10MHz response is within the target of  $-6dB$ . Do not forget, however, that this depends on the output 75Ω coaxial cable to the oscilloscope being no more than 12in long.

Measurements could not be made at low frequencies because of flicker. There is no measurable drop at 50Hz. At 20 Hz, the lowest frequency available, flicker was too great for any accuracy.

Thermal drift is satisfactory, although not entirely absent. Altering a gain control does produce some shift of the trace. This is very evident when there are no input signals. With signals, which is when one wants to use the controls, the shift is hardly noticeable. Varying  $V_{cc}$  also produces trace shift, but again this is trivial in normal usage.

### Setting up

Switch on and check  $V_{cc}$ , which should be 12V approximately. Connect a 10-V meter from earth to  $Tr_3$  emitter and adjust  $R_{12}$  ( $V_{B1}$ ) for 2.7V with gain set at minimum.

Transfer the negative meter lead from earth to the emitter of  $Tr_4$  and adjust  $R_{11}$  ( $V_{B6}$ ) for zero volts, doing this finally on the 50μA range of the meter. Connect a 10-V meter from earth to  $Tr_8$  base through a small resistor (e.g. 470Ω) at the  $Tr_8$  end of the meter lead to prevent the meter lead causing instability. Set the shift control at its mid position. Adjust  $R_{10}$  ( $V_{B8}$ ) for 2.7V.

Repeat with the other amplifier. Do not



alter the shift control setting between adjustments of  $V_{B8A}$  and  $V_{B8B}$ .

Check that the amplifiers and switching circuits are working and that there are no obvious faults. Leave the unit operating for an hour or so, for it to attain a stable temperature and repeat all bias adjustments carefully.

### Probe and attenuator adjustments

The gain controls have no effect on these, but adjustments are normally made at or near full gain. A square-wave signal of very roughly 1kHz repetition frequency is needed. If a separate generator is available this should be used.

Connect both probes to the generator and set all attenuators to the  $\times 1$  positions. Adjust the generator output and the shift control so that two separated traces are secured on the oscilloscope, each of about one-half the available screen size. Adjust the probe trimmers for square corners to the waves. (This assumes that the generator wave is itself square and this should be checked. If it is not, the adjustment must be to make the displayed wave the same as the generator wave.) Adjustment of the trimmer will affect only diagonal corners. If the wave is displayed in the usual way positive upwards and time increasing to the right, then top left-hand and bottom right-hand corners will be affected. Too much trimmer capacitance will cause overshoot, too little, rounded corners. It may happen that slightly different adjustments are needed to obtain both upper and lower corners dead square. In the original instrument this occurred to only a slight degree. It is caused by the input capacitance of the amplifier changing slightly with signal voltage. There is not much that can be done about it, but the effect should be very small. We found that with the top corners square, the bottom ones had an overshoot of rather less than the trace thickness. The probe adjustments are very critical.

If both probes are correctly adjusted and everything is in order, it should be possible by critical adjustment of the gain and shift controls, to superimpose the two traces so well that it is barely possible to detect that there are two.

Now connect in turn each input socket of the unit to the generator by a cable (not the probe). A smaller input will be needed. Put the 3:1 attenuators in circuit and adjust  $C_4$  in exactly the same way as the probe trimmer. If there is overshoot still with  $C_4$  at its minimum,  $C_5$  is too small and extra capacitance should be added; 10pF will probably suffice. All is well when there is a definite optimum setting for  $C_4$ .

Next put the 3:1 attenuator out of circuit, bring in the 10:1 and increase the input. Now adjust  $C_7$ . Again, if there is overshoot at the minimum setting; increase  $C_8$ .

The final step is to adjust  $C_3$  and  $C_6$ . Connect the unit to the generator using the probes and increase the input as necessary. Adjust  $C_3$  with the 3:1 section in circuit and then  $C_6$  with the 10:1 section only. The adjustments are always for square corners.

Put both attenuators in circuit and check the waveform. There are no adjustments

here, and any appreciable change indicates a fault. The most probable cause is that the adjustments have not been made carefully enough and that errors have accumulated. Note, however, that the merest trace of stray coupling across both attenuator sections will cause severe overshoot. This is the reason for the careful screening.

If no signal generator is available, alignment can be done with bistable output. Disconnect the leads at 13A and 13B from Board C. Connect one lead to earth and the other to 6 of its own board. This is readily done on the appropriate tag of  $R_{11}$ . This will turn on  $Tr_9$  in one board and turn off  $Tr_9$  in the other, so  $Tr_8$  in the first will be off and  $Tr_8$  in the second will be on. The probe of the 'on' channel is now connected to the appropriate point on the chain of resistors forming  $R_{C5}$  of the bistable to get the required output and the frequency is adjusted to about 1kHz. This can, of course, be checked with the oscilloscope, which should also be used to check the waveform.

The adjustments are carried out exactly as before and when all in one channel have been completed, the '13' leads are reversed to switch over to the other channel, which can then be adjusted.

There are two disadvantages in using the internal generator for alignment. The first is the need for altering internal connections, the second is that it is impossible to superimpose traces from the two channels to check the identity of the two channels. If a separate pulse generator is desired, it need only be a duplicate of Board C, with the omission of  $Tr_3$  and its associated components and the switching. A single capacitor of about 0.003 $\mu$ F will suffice for the sawtooth generator. We made one up for this purpose and found it most convenient.

The only other adjustments are to the pre-set gain controls. One must be set for unity gain with inputs to the probes and the attenuators all at  $\times 1$ . To do this accurately apply about 0.5V r.m.s. sine wave at about 1kHz to a probe and use a voltmeter or equivalent, which need not be calibrated, to check the input. Change the '13' leads from the bistable as described above so that only that channel is operative, and transfer the meter to the output. Adjust the appropriate pre-set gain  $R_3$  for the same reading on the meter. Check carefully. Replace the connections to normal and apply an input to both probes, adjust the other pre-set gain control and the shift control to obtain exactly superimposed traces. This equalizes the gains of the two channels. All adjustments are, of course, carried out with both panel gain controls at maximum gain.

Some people may feel it is unnecessary to have a basic maximum gain of unity. It all depends on what one wants the unit for. If it is not needed,  $R_3$  can be omitted from both channels if  $R_1$  is increased, to about 100 $\Omega$ . Equality of gain can be obtained at any time just by connecting both probes to the same signal, having the same attenuator settings in both channels, and adjusting the panel gain controls and shift to superimpose the two traces.

One final point should be mentioned. When using the internal sawtooth generator to control the switching very narrow

positive-going pulses of about 2V amplitude appear on the display whenever the switch operates. They also exist when the bistable is triggered by the timebase of the c.r.o., but they cannot be seen because they occur during the flyback of the trace.

In normal usage they are hardly visible because the c.r.o. timebase is locked to the signal and the internal sawtooth generator is not. The pulses thus tend to form a faint even background to the signal which is hardly noticeable. They can be seen clearly if without a signal the oscilloscope is set for internal synchronization, so that its timebase is triggered by the pulses. They are of rather less than 2 $\mu$ s duration.

When a bistable is triggered it is necessary for there to be a period when both its transistors are simultaneously conductive, otherwise there could not be loop gain or a regenerative action. The collector voltage of one transistor rises while that of the other falls, and these changes are conveyed by the switching transistors, which are really emitter-followers, to the amplifier transistors of the two signal channels. According to the precise waveforms occurring during the bistable transitions, both signal transistors can be on or off together, to produce negative or positive output pulses.

Normally they are both off together, or nearly so, and the output pulses are positive. If fairly large speed-up capacitors are fitted to the bistable, they will be on together and produce negative output pulses. With critical adjustment of small speed-up capacitors, each transistor can produce a waveform like one cycle of a sine wave. What happens depends on the difference between the two collector waveforms of the bistable during transition.

The front cover of this issue shows six oscillograms photographed from the screen of a cathode-ray oscilloscope which was fed by the dual-trace unit. The upper trace of each pair is for a signal applied to Channel A and the lower for one applied to Channel B.

The two top pairs of traces and the left-hand middle pair are for the same input to both channels, a square-wave generated by a duplicate of the switching generator of the dual-trace unit. In all three cases, the probe for Channel A was correctly adjusted. For the lower trace in each pair, the probe for the top left-hand pair had too much capacitance, that for the top right-hand pair had too little, while it was correct for the left-hand middle pair.

The right-hand middle pair shows the sawtooth at the emitter-follower output as the upper trace and one bistable output as the lower trace. The same sawtooth appears as the upper trace of the bottom left-hand pair, and below it the result of integrating the waveform by 100k $\Omega$  and 550pF.

At the bottom right is shown the result of applying a 10MHz sine wave to both channels and coalescing the traces by adjustment of the gain and shift controls. The superimposition of the two traces is not quite perfect, but only because the two controls could not be set quite accurately enough. There is barely a trace of phase difference, which well illustrates the accuracy obtainable in the adjustment of the probe responses, as well as in the amplifiers.

# Another PAL Decoder

## System used in Teleton portable colour television sets

by A. Becker\*

The Teleton Model VX1110 colour television receiver is now reaching the British market from the production lines of the General Corporation of Japan and it merits attention for the new concept of colour decoding which it employs. This is based on patents of circuits originally developed by Mr. Yasumasa Sugihara, technical director of the General Corporation, for the Colornet system intended for single-gun

colour tubes. In a modified form, it has found a new application.

Its salient features can best be understood by comparing Figs. 1 and 2, which illustrate the signal paths in a conventional PAL decoder and in the Teleton circuit respectively. For convenience sake, a PAL S decoder† is used in this illustration, but it is obvious that the methods used will apply equally well to full PAL.

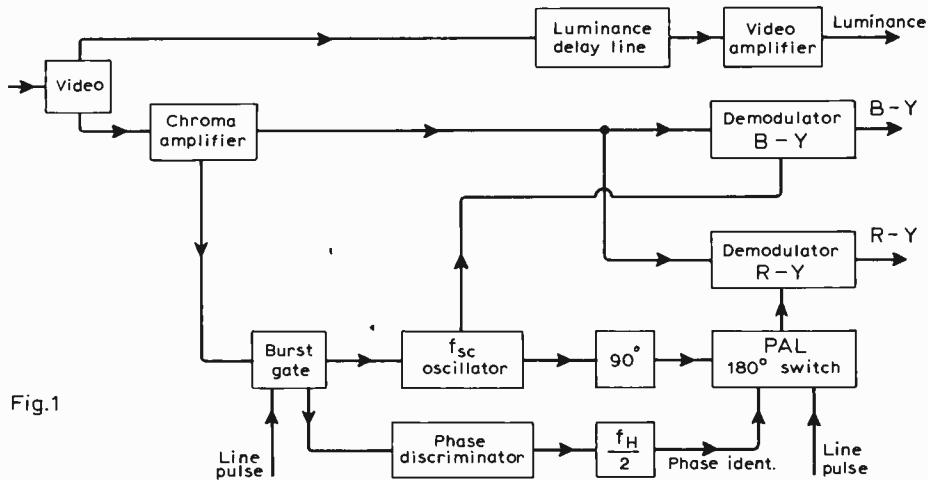

Fig. 1

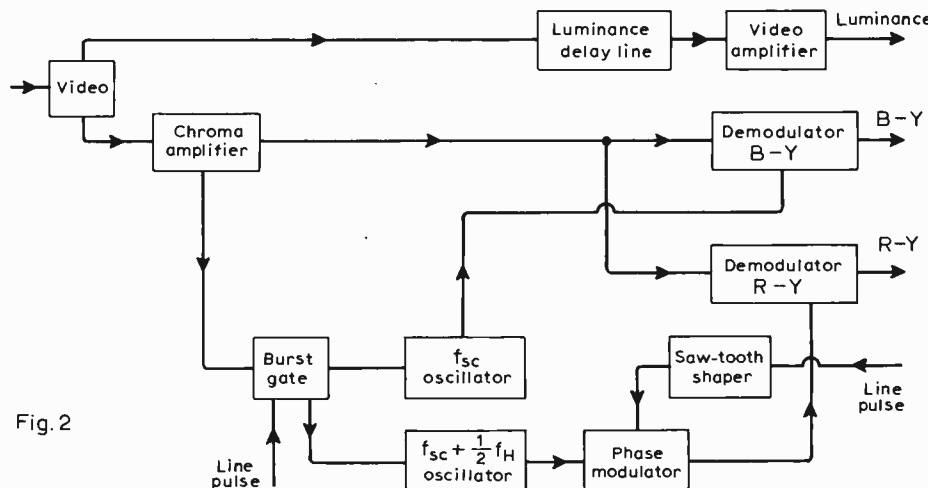

Fig. 2

Fig. 1 (above) Schematic of a conventional PAL decoder, for a 'Simple' PAL colour receiver, with Fig. 2 (below), schematic of decoder used in Teleton colour receiver  $f_{sc} = 4.43361875$  MHz (in text '4.43 MHz').

In both cases, the signal follows the usual triple path:

1. Through the luminance delay line to the luminance output stage.

2. Through the chroma amplifier/filter to the B-Y and R-Y demodulators.

3. Through the burst gate to the subcarrier regenerator.

While paths 1 and 2 are virtually identical in the two decoders, path 3 follows a different course in the new circuit. Instead of controlling a single oscillator, it is used to drive two different subcarrier regenerators — one at 4.43 MHz and the other at  $4.43\text{MHz} + \frac{1}{2}f_H$  (where  $f_H$  is the line scanning frequency). It should be mentioned here that a frequency of  $4.43\text{MHz} - \frac{1}{2}f_H$  would also satisfy the circuit.

The 4.43MHz subcarrier is taken direct to the B-Y demodulator, while the offset subcarrier is suitably processed to demodulate the R-Y signal according to the specific requirements of the PAL system. This processing takes place in functional units designated 'phase modulator' and 'saw-tooth shaper' in Fig. 2. Combined with the offset oscillator, they provide both phase switching and phase identification in the following manner.

Fig. 3(a) shows the colour burst at its repetitive rate of  $f_H$  whilst its phase is illustrated in (b). This swinging burst returns to the same phase every second line, i.e. it is modulated by a frequency of  $\frac{1}{2}f_H$ . This modulation produces sidebands either side of the burst's nominal frequency during transmission of the burst in the line blanking interval — see Fig. 4 —

\*Teleton Electro (U.K.) Co. Ltd.  
†PAL S means 'Simple' PAL, i.e. not using a delay line in the chrominance channel.

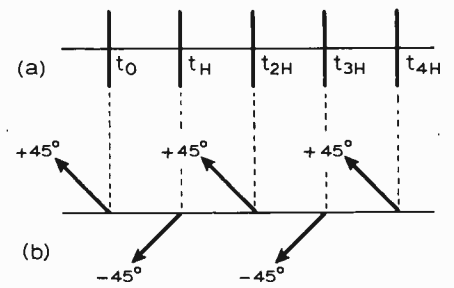

Fig. 3 (a) Sequence of colour synchronizing bursts occurring at the repetition rate  $f_H$ ; with (b), corresponding phase angles of the bursts (the 'swinging burst').

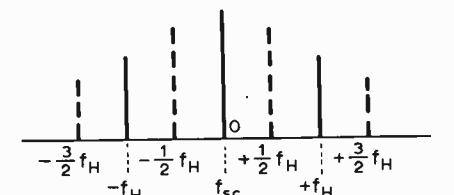

Fig. 4 Spectrogram showing the nominal frequency of the burst,  $f_{sc}$  and the sidebands resulting from its changing phase — equivalent to modulation by a frequency of  $\frac{1}{2}f_H$ .

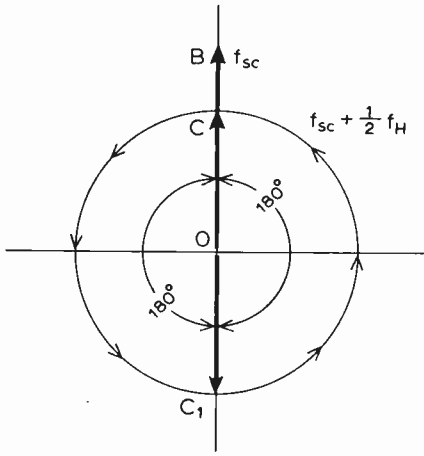

Fig. 5. Vector diagram for showing the timing relationship of  $f_{sc}$ , represented by vector  $OB$ , and  $f_{sc} + \frac{1}{2}f_H$ , represented by vector  $OC$ .

and we find within this spectrum the frequency components  $f_{sc} + \frac{1}{2}f_H$  and  $f_{sc} - \frac{1}{2}f_H$ . Choosing either of these for locking, an oscillator establishes a fixed phase relationship to one frequency of the swinging burst — in other words, it provides phase identification.

If we also compare  $f_{sc}$  and  $f_{sc} + \frac{1}{2}f_H$ , we find that the number of cycles contained in an interval of  $2f_H$  is exactly one cycle greater in  $f_{sc} + \frac{1}{2}f_H$ , which also means that it is advanced by  $\frac{1}{2}$  cycle, or  $180^\circ$ , for one line period. Fig. 5 illustrates this point.

Vector  $OB$  represents  $f_{sc}$  and vector  $OC$  shows  $f_{sc} + \frac{1}{2}f_H$  at the start of a line period.

At the end of the first line, vector  $f_{sc}$  is still in the same position but the other vector has moved to  $OC_1$ . At the start of the second line, they are both back at their original position. This means that  $OC$  is moving in an anti-clockwise direction, passing the  $180^\circ$  position at the end of one line and completing  $360^\circ$  every second line. If we were to use this vector to decode R-Y, we would have little satisfaction: a red horizontal line on the screen would gradually creep from red through yellow to green. What we need is a force to oppose the anti-clockwise movement until the end of the line and then let it flick forwards to the position it would have reached had it been left alone — i.e.  $180^\circ$ .

This function is fulfilled by the phase modulator, the action of which is shown in Fig. 6. Using a line-frequency saw-tooth waveform derived from the shaping circuit, it imparts a clockwise phase shift to the offset subcarrier during the line period and then allows it to regain its natural position during line blanking.

It can now be seen that this action is that of a PAL switch, and that the decoder embodies the essential functions for coping with a PAL signal:

1. It produces regenerated subcarriers for R-Y and B-Y.
2. It establishes phase identification by tuning the offset subcarrier oscillator to either the upper or lower sideband of the burst frequency spectrum — by the choice of either  $f_{sc} + \frac{1}{2}f_H$  or  $f_{sc} - \frac{1}{2}f_H$  for its crystal oscillation frequency.
3. It provides PAL switching.

Fig. 7 gives the actual circuit of the

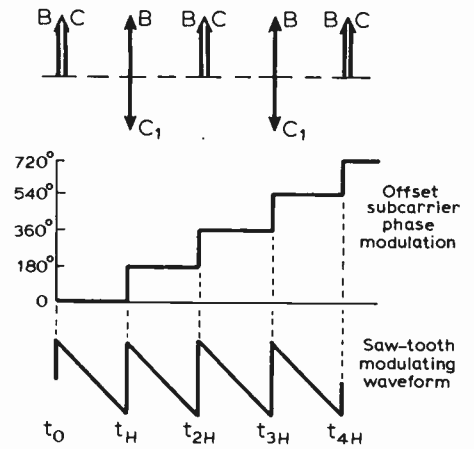
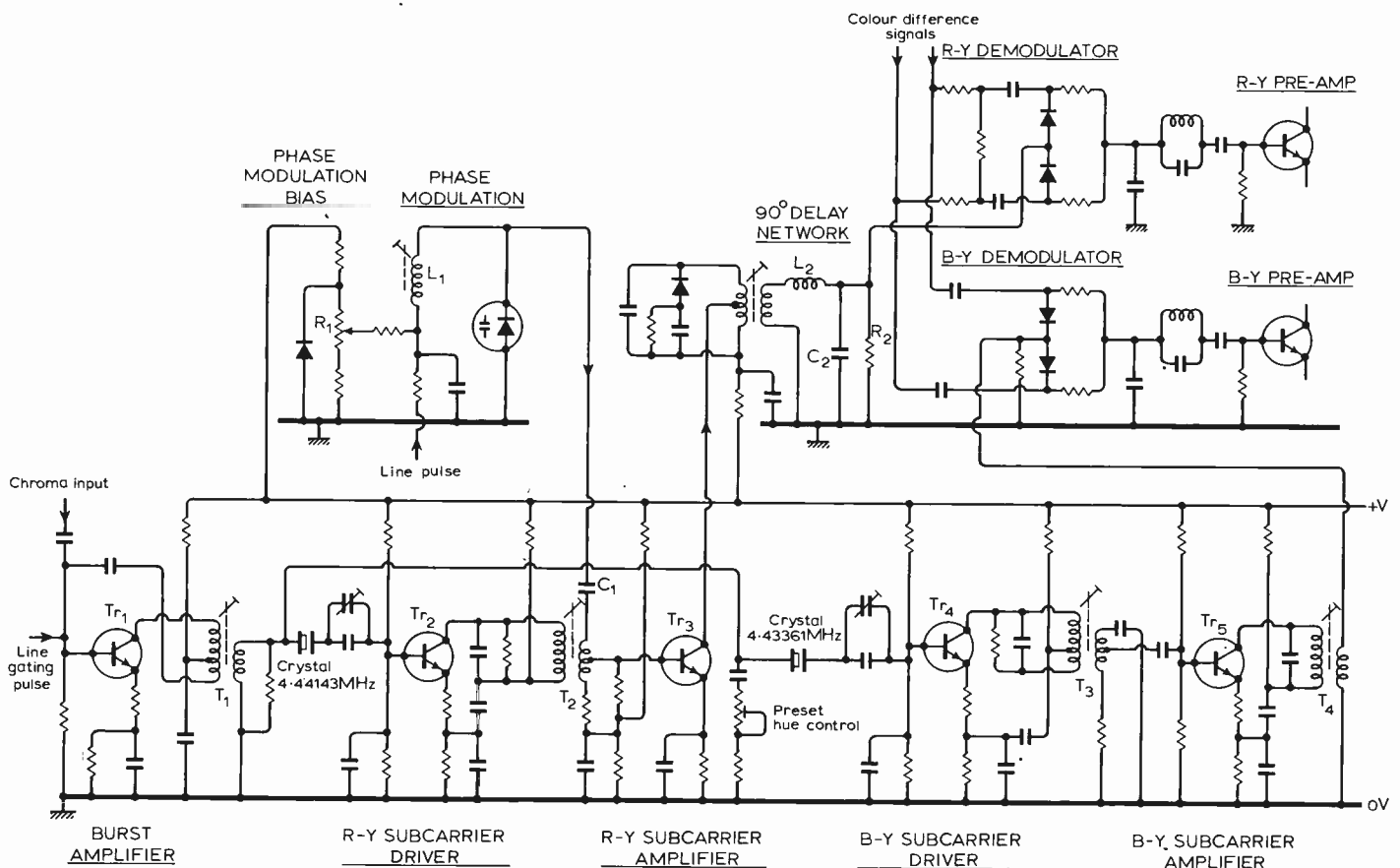

Fig. 6. Action of phase modulator, showing, from the bottom, saw-tooth modulating waveform, change of phase in steps and, at the top, vectors indicating phase alternation of offset subcarrier oscillation.

decoder and here we can recognise the practical equivalents of the blocks in the schematic Fig. 2. Transistor  $Tr_1$  is the common burst gate supplying both  $Tr_2$  and  $Tr_4$  with the colour synchronizing signal. Phase modulation is fed to  $C_1$  and the processed R-Y subcarrier is supplied to the demodulator via the  $90^\circ$  delay network consisting of  $L_2$ ,  $C_2$  and  $R_2$ .

The circuit is very insensitive to noise by the very nature of its concept, which is important in view of its use in a portable receiver.

Fig. 7. Relevant parts of colour receiver circuitry corresponding to functional blocks of decoder in Fig. 2.



# Electronic Building Bricks

## 19. The rectifier

by James Franklin

The rectifier is a device which will allow electrons to flow at a high rate in one direction in an electrical circuit, Fig. 1(a), but at a considerably lower rate in the opposite direction, Fig. 1(b). Ideally it can be considered as an automatic switch which is closed for one direction of electron flow — that is, made fully conducting — and opened, or made non-conducting, for the opposite direction of electron flow. In practice it behaves more like a special kind of resistance (Part 7) which has a low value for one current direction, known as the *forward* direction, and a very high value for the other direction, known as the *reverse* direction. In fact the ratio of the forward to reverse resistances is one measure of the effectiveness of a rectifier. This resistance ratio can range from about 1000:1 to 400,000:1, according to the type of rectifier.

The word rectifier\* covers a variety of devices, the most common being copper oxide rectifiers, selenium rectifiers, semiconductor (silicon or germanium) diodes and thermionic diodes. Although this series is not concerned with "hardware" as such, the function of rectification is so widely used in electronics that the rectifier must be considered as a "building brick" in itself. We have, in fact, used the graphical symbol for the component inside the function boxes in Fig. 1 as this has the virtue of indicating the directions of high and low electron flowrate for particular ways of connecting the e.m.f. source (polarities).

Some of the uses of the rectifier as an automatic switch are shown in Fig. 2. At (a) it is connected in a circuit between an e.m.f. source of alternating voltage (a.v.) — see Part 17 — and some other "building brick" (the circuit through which is indicated by the broken line). The e.m.f. source here produces a sinusoidal a.v. and because the rectifier is connected as shown it allows substantial current to flow only in the direction resulting from voltage values of positive potential (+), plotted upwards from zero in the "input" graph (Part 17). As a result the current in the whole circuit

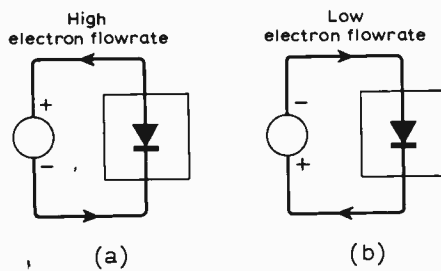

Fig. 1. A rectifier (shown as a box containing the graphical symbol for the device) connected to e.m.f. sources, (a) and (b), giving opposite directions of electron flow.

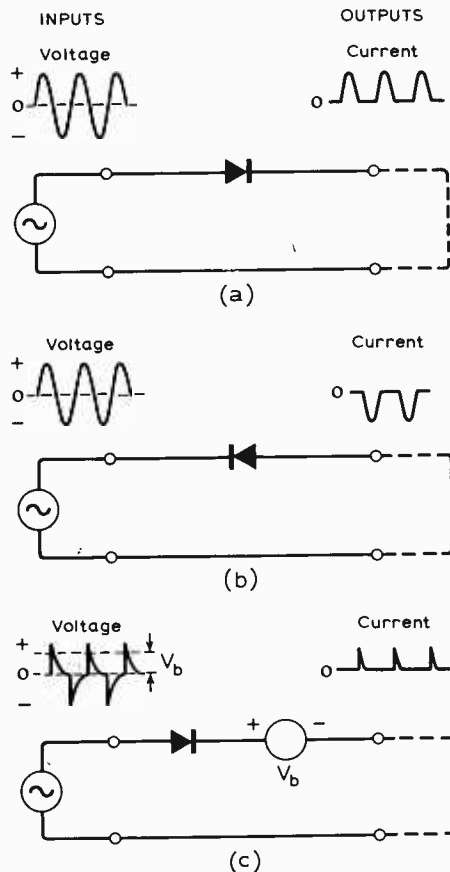

Fig. 2. Three ways of using a rectifier: (a) and (b) half-wave rectification giving uni-directional current pulses from an a.v. input; (c) effect of biasing the diode with a direct voltage,  $V_b$ .

is a series of uni-directional pulses, or pulses of d.c., corresponding to the top half of the voltage waveform. This process is known as half-wave rectification and is used most commonly for obtaining d.c. power from the a.c. mains and for recovering sound and vision information from a.c. carrier oscillations. Connecting the rectifier in the opposite way, as at (b), reverses the whole process and produces uni-directional pulses of current flowing in the opposite direction — resulting from voltage values of negative potential (-).

This process may be modified by applying direct voltages (d.v.) from e.m.f. sources in various ways to the rectifier. This is known as biasing. An example is shown in Fig. 2(c). Here the mode of operation is similar to that in (a) except that the rectifier is not allowing forward current to flow through it for all voltage values of positive potential from the a.v. source, because there is an opposing e.m.f. of value  $V_b$  inserted into the circuit by the d.v. source connected in series with the rectifier. The voltage from the a.v. source must exceed the opposing bias voltage  $V_b$  before any forward current can flow through the rectifier. When rectifier current does flow it is that resulting from the tops of the a.v. waveform as shown. (Note that the d.v. source itself cannot cause current to flow through the rectifier because of its polarity with respect to the rectifier.) This technique is used when only a part of a signal waveform is to be conveyed to the next building brick.

In Fig. 2 all the output signals are in the form of varying currents, but these could be changed into corresponding voltages by passing the current in each case through a resistance and thereby developing a potential difference across it.

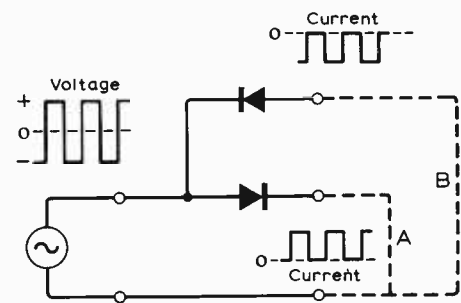

Fig. 3. Use of rectifiers for "steering" parts of input waveforms into different circuits, A and B.

A further application of the rectifier is the switching of parts of waveforms having different voltage polarities into different circuits or building bricks. This is called "steering" and is illustrated in Fig. 3. From the explanation of rectifier action above we can see that the voltage excursions of positive polarity (plotted upwards from zero) will cause corresponding current excursions in circuit A while voltage excursions of negative polarity (plotted downwards) will cause corresponding current excursions in circuit B.

\* Possibly based on the ordinary verb 'rectify' (put right, correct, reform etc.) or on the geometrical term 'rectify' which means to find the length of a curved line.

# High-voltage Constant-current Source

## Control of a d.c. thyristor power supply using an opto-electronic feedback loop

by D. A. Williams

The basic circuit is shown in Fig. 1. Feedback is arranged so that reduction of load resistance causes a proportional reduction in supply voltage — an increase in current through the load causes the light emitter (a small filament lamp) to radiate more light. If the light sensor is a cadmium sulphide photo-resistor, then the resistance of this device will drop, and the change can be used to retard the firing angle of thyristors in the d.c. power supply.

This technique avoids the need for a direct connection between power and control sections. The only significant disadvantage of opto-electronic feedback is the response time, which is insufficiently short to cope with fluctuations occurring at intervals smaller than a few milliseconds. Long-term stability can be very good.

Fig. 2 shows the circuit of a d.c. power supply developed for use with a continuous-wave magnetron. This required approximately 900V stabilized at 30mA. The series combination of two thyristors and a diode, paralleled with  $R_1$ ,  $R_2$  and  $R_3$ , may seem rather strange, but the reasons for doing this are simple.

To obtain the necessary output voltage  $T_1$  was chosen to give a secondary voltage of 1.5kV r.m.s. at 50mA. If the load drew no current then  $C_1$  would charge to roughly -2.1kV and, on the positive excursion of the a.c. supply, approximately 4.2kV would be applied across the rectifier system in the reverse direction. Unfortunately no single readily available thyristor can withstand such a reverse voltage without breaking down, but placing a diode in series with the thyristor protects against this. However, this does not explain the need for two thyristors in series. These are required to withstand a peak forward voltage of greater than 1.5kV and remain non-conducting until they are fired by a pulse from  $T_3$ . Although single thyristors are available to withstand forward voltages of 1.5kV they are expensive and it proves much more economical to use two cheaper thyristors in series.

Resistors  $R_1$ ,  $R_2$  and  $R_3$  pass a current approximately ten times the leakage current of the thyristors and rectifier, and distribute the reverse voltage evenly between the three devices. Because of their

high values they do not significantly upset the smoothing of the supply. The half-wave pulses are smoothed from the rectifier system by  $R_4$  and  $C_1$  and  $R_5$  limits the maximum possible output current.

### Control circuit

The thyristors in the circuit are 'phase fired' — control of output voltage is achieved by delaying the firing of the thyristors until some time after the start of the negative half sine wave. The output

voltage can be varied by varying the delay time.

The firing pulses are generated by a unijunction relaxation oscillator isolated from the high-voltage circuit by a pulse transformer. If the supply to this circuit is a square wave, then the time after the start of the square wave at which a pulse is produced is given by

$$t = CR.$$

The complete circuit of the controller is shown in Fig. 3. The l.d.r. together with  $R_7$  forms a potential divider at the base of the p-channel enhancement mode m.o.s.f.e.t. A drop in cell resistance will cause a drop in gate-source voltage and this will produce an increase in channel resistance which will, in turn, cause an increase in  $t$  and a drop in output voltage.

### Design considerations

The best stabilization is obtained from the system if, at the desired output current, the thyristors are fired near the peak of their supply waveforms. This allows the firing point to swing about the peak for varying load conditions (Fig.4). Thus, a firing pulse must be generated 5ms after the start of the negative half cycle:

$$\text{thus } t = 5 \times 10^{-3} \text{sec.}$$

Let  $C_2 = 0.1\mu\text{F}$ , then  $R_{\text{channel}} = 50k\Omega$ . The m.o.s.f.e.t. used gave this channel resistance at a gate-source voltage of approximately -7.7V. In the practical

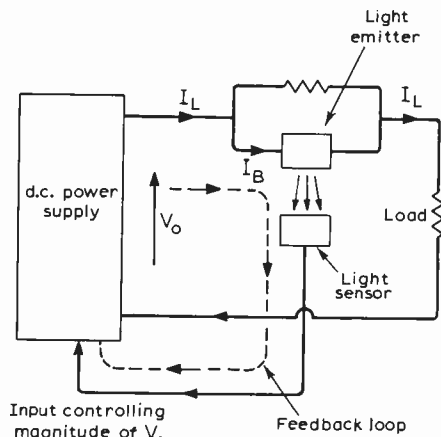

Fig. 1. Basic circuit of opto-electronic current controller.

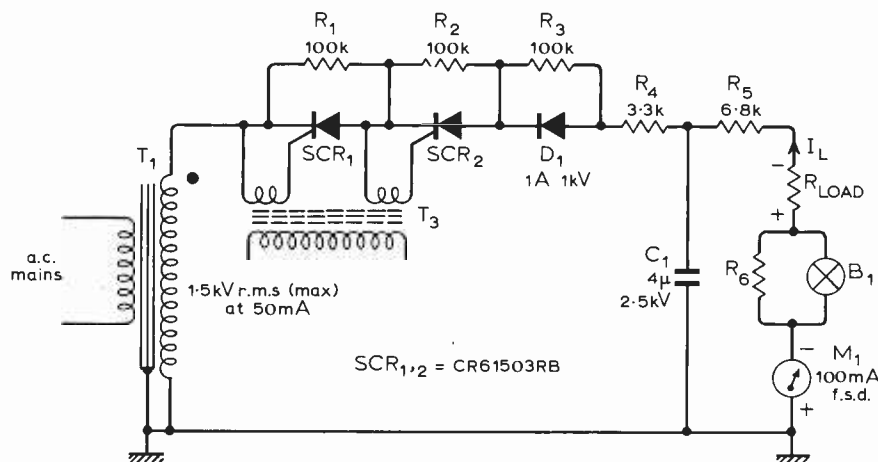

Fig. 2. Practical circuit of high voltage current supply. Using two thyristors and a diode rather than one very high voltage thyristor results in a cost saving.

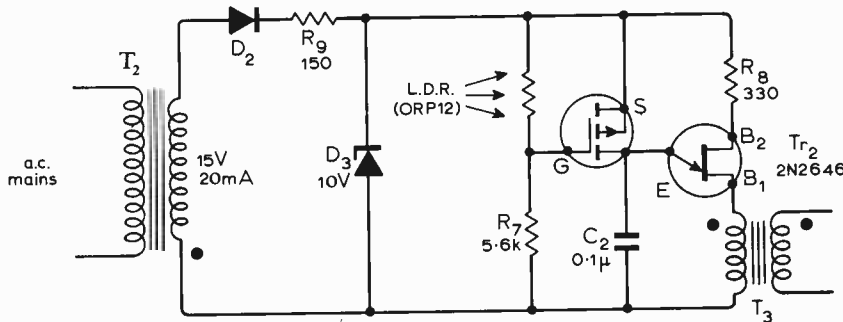

Fig. 3. Low-voltage control circuit. The unijunction transistor is supplied with a 10V square wave of opposite phase to the thyristor circuit supply.

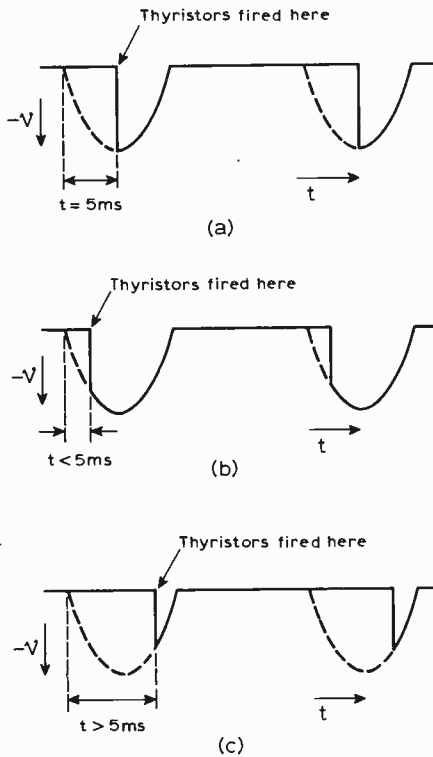

Fig. 4. Optimum firing conditions for good current stabilization.

Fig. 7. (Below). An a.c. constant current circuit. The rectifiers and thyristor are selected for required load current.

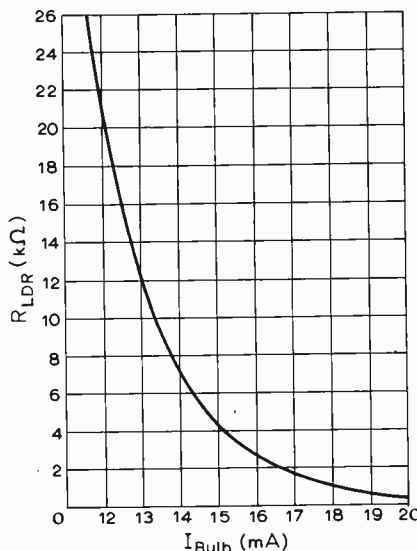
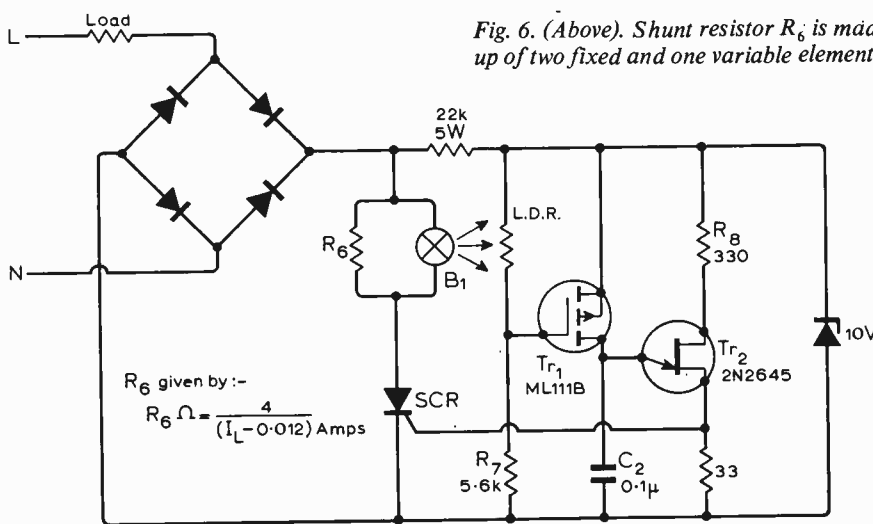

Fig. 5. Graph of cadmium sulphide cell resistance plotted against bulb current.

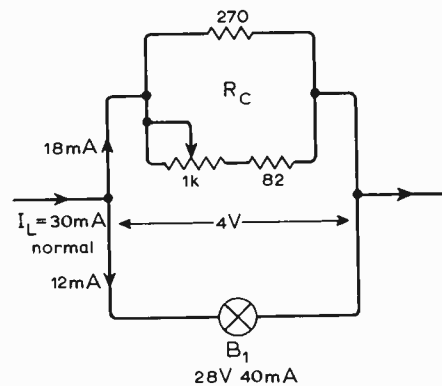

Fig. 6. (Above). Shunt resistor  $R_6$  is made up of two fixed and one variable element.

system, the bulb (28V, 40mA) was mounted facing the l.d.r. in a Paxolin tube.

To calculate the value of  $R_7$ , a graph, shown in Fig. 5, was plotted of l.d.r. resistance versus bulb current. It can be seen that the steepest part of the curve is around a bulb current of 12mA. Thus, if the bulb takes this current with the output current at its desired value, any small change in output current will cause a large change in l.d.r. resistance, and maximum control sensitivity is obtained. At a bulb current of 12mA, the l.d.r. exhibits a resistance of about 20kΩ. The resistance of  $R_7$  works out about 5.6kΩ. Referring back to Fig. 3 the components  $D_2, R_9, D_3$  serve to generate a square wave supply to the controller in antiphase to the thyristor supply. In the application stated the required stabilized output current was 30mA. This required  $R_6$ , made up as shown in Fig. 6, to be 220Ω to provide 12mA through the bulb. The 1kΩ potentiometer allows a range of adjustment of the output current between 25 and 35mA.

### Operation of system

If a load resistor with a value of 33kΩ and 30W dissipation is connected into the circuit and the equipment is switched on, the output current will rise very rapidly to 30mA (or thereabouts) and then stabilize to that value. It should now be possible to vary  $R_L$  between 0 and 100kΩ and the output current should be maintained at 30mA.

When the circuit is operating with a load of about 30kΩ and at 30mA output current, the ripple voltage across the load is no greater than 30V — corresponding to an output current ripple of approximately 1mA p-p. Because of the relatively crude smoothing circuit used, ripple amplitude gradually increases as the load resistance is dropped, but if the system is required to work under different load conditions then there is no reason why the smoothing circuit should not be designed to suit a particular application.

Although this system has been developed specifically as a high-voltage source, there is no reason why a similar system should not be used to obtain a constant d.c. (or a.c.) current at low voltage.

At low voltages, only one thyristor need be used and the voltage sharing resistances can be dispensed with.

As an a.c. constant current source, a bridge rectifier can be employed with the thyristor; and if isolated operation is not required  $T_2$  and the pulse transformer can be dispensed with, as in Fig. 7.

Even though the bulb may only draw a few milliamps at its operating brightness, there is no reason why the system should not provide stable currents of up to hundreds of amps, so long as the bulb is shunted by a suitably low resistance.

### Components

Thyristors type CR6 1503 RB cost £9.45 each, and pulse transformer PT4 101p, direct from A.E.I. Semiconductors Ltd, Carholme Road, Lincoln.

# T.T.L. Trigger Circuits

by H. A. Cole\*, M.I.E.R.E.

Nand-gate t.t.l. circuits are described which produce short-duration pulses coincident with the leading or trailing edges of a long-duration input waveform. A novel three-gate circuit is also described which produces short-duration output pulses coincident with both leading and trailing edges of the applied waveform.

It is sometimes desirable, when setting or resetting a flip-flop, for example, to produce a short-duration pulse coincident with the leading or trailing edge of a longer-duration pulse.

A circuit to perform this function may be constructed from a pair of t.t.l. nand-gate elements<sup>1</sup>, connected as shown in Figs. 1 and 2<sup>2</sup>. Whether such circuits produce a pulse on the leading or trailing edge is determined by the polarity of the applied input waveform. In Fig. 1 the application of a logical-1 input (about 3.5V) results in an output pulse coincident with the leading

\*Electronics & Applied Physics Division, A.E.R.E. Harwell.

edge of the input waveform. On the other hand, the application of a logical-0 input (near-zero) results in an output pulse coincident with the trailing edge of the input waveform.

The circuit shown in Fig. 2 is the complement of Fig. 1. It produces an output pulse on the leading edge of the waveform for a logical-0 input and vice versa.

### Operation

In each type of circuit, the output pulse is produced by the artificial delay introduced by the integration circuits formed by the components labelled  $R_1$  and  $C_1$ . The delay

has the effect of prolonging the 1-to-0 transition at one of the inputs to gate two ( $G_2$ ), thereby allowing a momentary 1-to-0 transition to occur at  $G_2$  output (point D). In Fig. 1 the input terminal of  $G_2$  (point C) is unable to follow the abrupt transition which occurs at the output of  $G_1$  (point B), due to the discharging time constant formed by  $C_1$ ,  $R_1$ . Because of this, both input terminals of  $G_2$  are momentarily held at a logical-1 level and its output terminal therefore changes to the logical-0 state. Gate two remains in this operating condition until the voltage across  $C_1$  has decayed to a value ( $v^1$ ) which will be recognized by  $G_2$  input as being a minimum acceptable 1-level.

The circuit shown in Fig. 2 functions in the same way as that of Fig. 1, except that the delayed input to  $G_2$  is derived from the input (point A), instead of from point B.

### Output pulse duration

The duration ( $t_d$ ) of the output pulse is determined from the expression:

$$v^1 = V e^{-t_d/C_1 \cdot R_1}$$

from which;

$$t_d = C_1 \cdot R_1 \log_e(V/v^1) \quad (1)$$

( $V$  is the 1-level voltage to which  $C_1$  is normally charged, as shown in Figs. 1 and 2.)

Substituting 3.3V for  $V$ , and 1.4V for  $v^1$  (see pages 12 and 13 of reference 1), expression (1) becomes:

$$t_d = C_1 \cdot R_1 \log_e(3.3/1.4)$$

$$\text{or } t_d = 0.86 C_1 \cdot R_1.$$

Practical results, however, indicate that a more accurate expression for  $t_d$  is given by:

$$t_d = 1.3 C_1 \cdot R_1 \mu s \quad (2)$$

where  $C_1$  is expressed in microfarads, and  $R_1$  in ohms.

The maximum permissible value for  $R_1$  is about 220Ω for normal-power t.t.l., and about 2.2kΩ for low-power t.t.l. (see page 48 of reference 2). If these maximum values are used for  $R_1$ , so that the value of  $C_1$  may be kept as small as possible, the expressions for  $t_d$  become:

$$t_d = 2.9 \times 10^2 C_1 \mu s \quad (\text{normal-power t.t.l.}) \quad (3)$$

$$\text{and, } t_d = 2.9 \times 10^3 C_1 \mu s \quad (\text{low-power t.t.l.}) \quad (4)$$

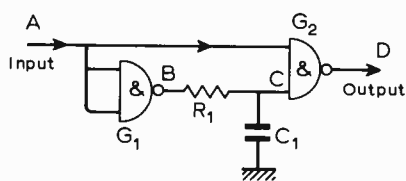

Fig. 1. A simple monostable element which will produce an output pulse on the leading edge of a logical-1 input pulse.

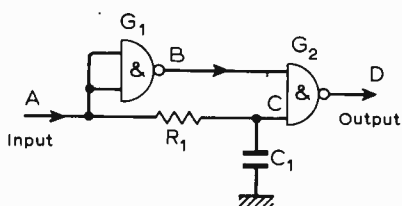
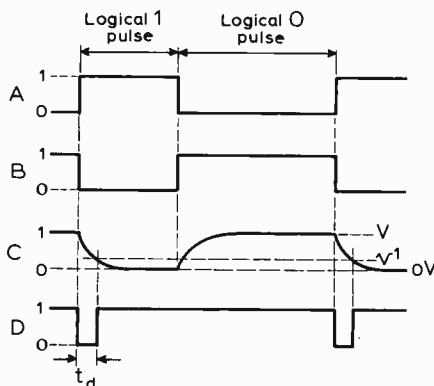
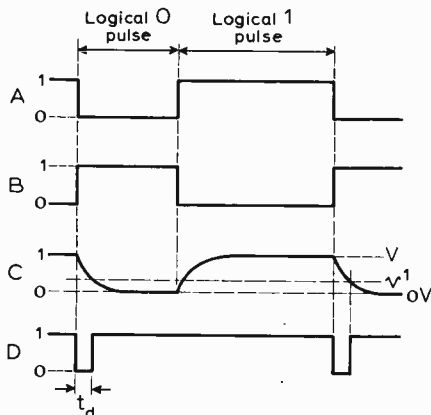

Fig. 2. As Fig. 1 except that the output pulse occurs on the trailing edge of a logical-1 input pulse.



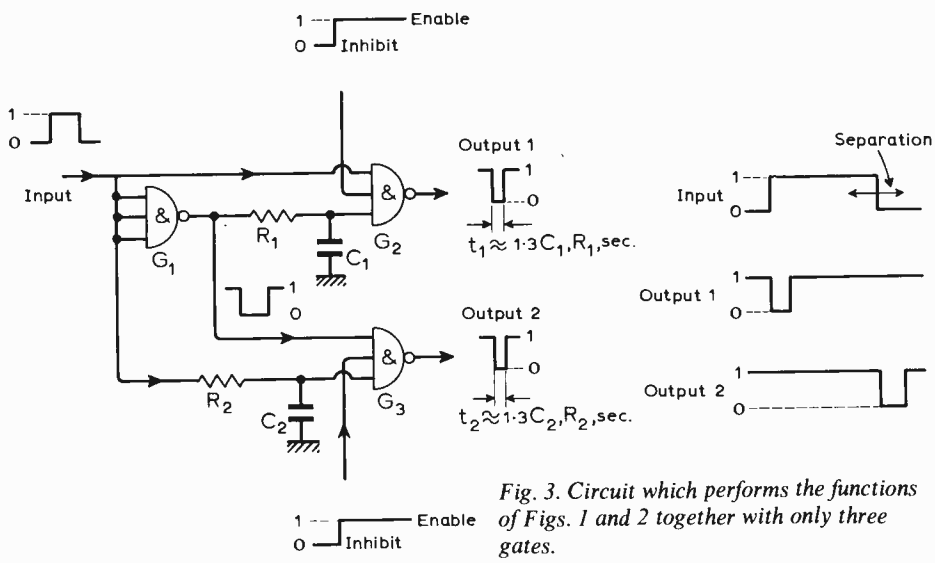

Fig. 3. Circuit which performs the functions of Figs. 1 and 2 together with only three gates.

For a circuit which will produce an output on a leading edge the maximum permissible value of  $t_d$  is limited by the duration ( $t_i$ ) of the input waveform, and the time-constant formed by  $C_1, R_1$ . If five full time-constants ( $5C_1 \cdot R_1$ ) are allowed for the total discharge of  $C_1$  during the presence of the input waveform, then:

$$t_{i(\min)} = 5C_1 \cdot R_1,$$

or,  $(C_1 \cdot R_1)_{\max} = t_i/5.$

Substituting this value of  $C_1 \cdot R_1$  in expression 2,

$$t_{d(\max)} = 1.3 \times t_i/5,$$

or,  $t_{d(\max)} = 0.26 t_i$  (5)

For this type of circuit a useful 'rule-of-thumb' is: the maximum permissible output pulse duration is approximately equal to one quarter of the input pulse duration.

Similar limitations exist for the maximum permissible output pulse produced by the circuit for an input trailing edge. In this case, however,  $t_{d(\max)}$  is limited by the separation period ( $t_s$ ) between successive input pulses. If, as before, five time-constants are allowed for the full recovery of  $C_1$  during the period  $t_s$ , then the expression for  $t_{d(\max)}$  becomes:

$$t_{d(\max)} = 0.26 t_s$$
 (6)

For these circuits, then, the rule-of-thumb is: the maximum permissible output pulse duration is approximately equal to one quarter of the input pulse separation period.

**Repetition rate**

The maximum permissible repetition rate ( $f_{\max}$ ) for the input signal is determined by the duration of the input pulse ( $t_i$ ), and the recovery time of  $C_1$  (see Fig. 3). If five full time-constants are allowed between the end and beginning of successive input pulses:

$$f_{\max} = \frac{1}{t_i + 5C_1 \cdot R_1} \text{ MHz} \quad (7)$$

where  $t_i, C_1$  and  $R_1$  are expressed in  $\mu\text{s}, \mu\text{F}$ , and ohms, respectively.

From expression (2)  $f_{\max}$  may also be expressed as:

$$f_{\max} = \frac{1}{t_i + 5t_d/1.3} \text{ MHz.}$$

or,  $f_{\max} \doteq \frac{1}{t_i + 4t_d} \text{ MHz}$  (8)

where  $t_i$  and  $t_d$  are expressed in  $\mu\text{s}$ .

**Two-pulse generation**

When short-duration output pulses are required from both leading and trailing edges of the input waveform, the circuits shown in Figs. 1 and 2 can be used together—sharing a common input terminal. On closer inspection of such a circuit, however, it is seen that the first gate of circuit 2 can be replaced by the first gate of circuit 1 (and vice-versa) since both are being used to complement the same input waveform.

A simplified circuit arrangement in which only three gates are required is shown in Fig. 3. This circuit is constructed from a triple-input nand-gate (e.g. SN7410N) so that the presence, or absence, of either output pulse can be controlled by the application of 'enable/inhibit' logic levels to the third input terminals of gates two and three.

The duration of each output pulse can, of course, be determined independently by suitable choice of  $C_1, R_1$  and  $C_2, R_2$ , in accordance with expressions 2, 3 and 4.

**References**

1. 'Mullard t.t.l. Integrated Circuits; Applications', 2nd Ed. (1970).
2. 'Semiconductor & Components Data Book'. Texas Instruments (1968).

**H.F. Predictions — January**

With a view to increasing the utility of these charts, produced for us by Cable and Wireless Ltd, changes have been made to two of the parameters presented. First, MUF (median usable frequency) is replaced by HPF (highest probable frequency) which is the MUF exceeded on 10% of the days. Secondly, FOT (optimum traffic frequency) has the same definition as previously but is no longer a constant 85% of MUF.

HPF and FOT are derived from MUF by applying factors having diurnal, seasonal, sunspot and geographic variations, which describe the distribution of daily values of standard MUF about their monthly median.

MUF can be approximated from the curves as being at mid-distance (not mid-frequency) between HPF and FOT.

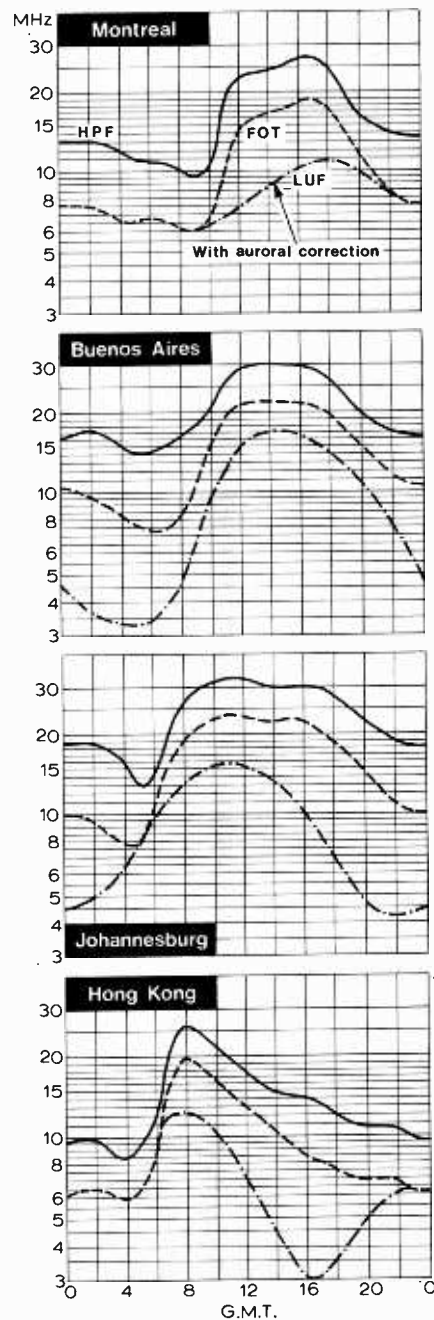



# Experimental Electronic Electricity Meter

A junction thermocouple multiplier is used in this Wh meter which the author proposes as a possible alternative to present electro-mechanical meters

by L. A. Trinogga\*

The aim of the project was to study the feasibility of replacing the domestic electricity meter, which employs a rotating disc, by an electronic meter. The quality and cost of an electronic electricity meter depends almost entirely on the multiplier which measures the power consumption of the load. The energy is the time integral of the power and can be expressed as

$$E = \int_0^t [I(t) \cdot V(t)] dt \quad (\text{Wh})$$

In order to measure the energy, the two voltages, one due to the load current and the other due to the load voltage are applied to the thermocouple multiplier.

### Vacuum thermocouple multiplier

The multiplier works on the 'quarter square' principle:

$$xy = \frac{1}{4}[(x+y)^2 - (x-y)^2]$$

The output from a thermojunction is

\*Department of Physics and Physical Electronics, Newcastle-upon-Tyne Polytechnic.

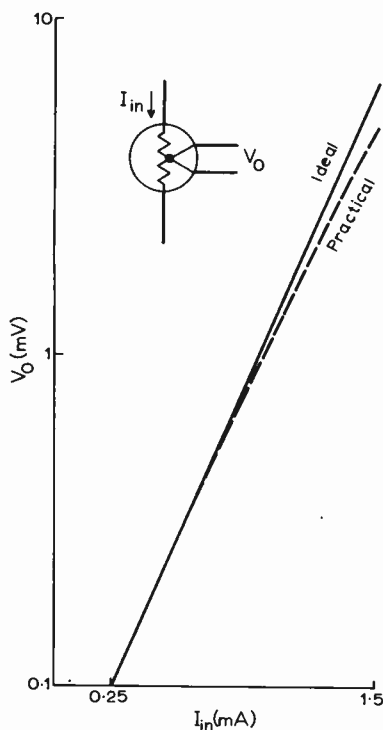

Fig. 1. How a typical thermocouple departs from the ideal square law characteristic.

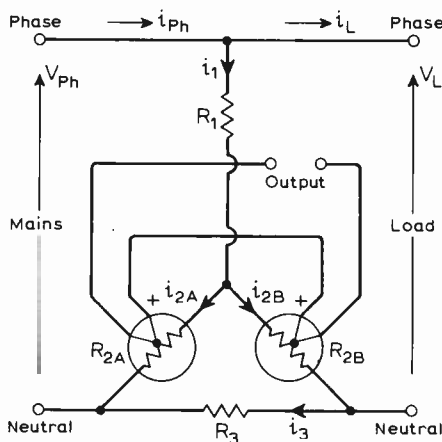

Fig. 2. The thermocouple multiplier.

approximately proportional to its temperature which, in turn, is approximately proportional to the square of the current flowing through the heating wire. The characteristic of a thermocouple is shown in Fig. 1 on a double logarithmic scale. The departure from the ideal square law is illustrated.

In the practical circuit two thermocouples are used and connected as shown in Fig. 2. The current through the thermocouples, which is limited by  $R_1$ , is proportional to the mains voltage  $V_{Ph}$ . When a load is connected across the output terminals (*Ph* and *N*) most of the load current flows through  $R_3$  developing a voltage across it. A fraction of the load current passes through the thermocouples whose heater resistances are denoted by the symbols  $R_{2A}$  and  $R_{2B}$ . With regard to the above equation the current  $i_{2A} \equiv +y$  and  $i_{2B} \equiv -y$ . The part of the load current that does not flow through  $R_3$ , but through the two thermocouples, is identical to  $x$ .

The following calculations prove this argument and enable the values of  $R_1$  and  $R_3$  to be determined so that the maximum error due to the circuit is below 1%.

$$i_1 R_1 + i_{2B} R_{2B} = V_L \quad (1)$$

$$i_1 R_1 + i_{2A} R_{2A} - i_3 R_3 = V_L \quad (2)$$

$$i_L = i_3 - i_{2B} \quad (3)$$

$$i_1 = i_{2A} + i_{2B} \quad (4)$$

Substituting (4) into (1)

$$i_{2B}(R_{2B} + R_1) + i_{2A} R_1 = V_L \quad (5)$$

Substituting (3), (4) into (2)

$$(i_{2A} + i_{2B})R_1 + i_{2A}R_{2A} - (i_L + i_{2B})R_3 = V_L$$

or

$$i_{2B}(R_1 - R_3) + i_{2A}(R_1 + R_{2A}) = V_L + i_L R_3 \quad (6)$$

From (5) one obtains

$$i_{2A} = \frac{V_L - i_{2B}(R_1 + R_{2B})}{R_1}$$

and from (6)

$$i_{2A} = \frac{V_L + i_L R_3 - i_{2B}(R_1 - R_3)}{R_1 + R_{2A}}$$

Equating the last two expressions and solving for  $i_{2B}$

$$-i_{2B} = \frac{i_L R_1 R_3 - V_L R_{2A}}{R_1 R_3 + R_1(R_{2A} + R_{2B}) + R_{2A} R_{2B}} \quad (7)$$

From this equation it can be seen that the thermocouple current  $i_{2B}$  is a function of load current  $i_L$  and output voltage  $V_L$ .

Hence

$$-i_{2B} = K(i_L - V_L)$$

Similarly equations (5) and (6) can be solved for  $i_{2B}$  and then be equated. Solving this for the current through thermocouple A gives

$$i_{2A} = \frac{V_L(R_{2B} + R_3) + i_L R_3(R_1 + R_{2B})}{R_1 R_3 + R_1(R_{2A} + R_{2B}) + R_{2A} R_{2B}} \quad (8)$$

The denominators in equations (7) and (8) are the same. Comparing the numerators yields

$$R_{2A} \equiv R_{2B} + R_3 \quad \text{for } V_L$$

and

$$R_1 \equiv R_1 + R_{2B} \quad \text{for } i_L$$

The last two expressions become identities if

$$R_3 \ll R_{2B} \quad \text{and} \quad R_1 \gg R_{2B}$$

This condition is satisfied since the thermocouple heater resistances  $R_{2A}$  and  $R_{2B}$  are about  $400\Omega$  and  $R_3$  is a fraction of  $1\Omega$ .

If a maximum error of 1% is tolerated, then  $R_3$  must not exceed

$$R_3 \text{ max} = \frac{R_{2A}}{100} = \frac{R_{2B}}{100} = \frac{400}{100} = 4\Omega$$

and  $R_1$  must have a minimum value of

$$\begin{aligned} R_1 \text{ min} &= R_{2A} \times 100 = R_{2B} \times 100 \\ &= 400 \times 100 \\ &= 40\text{k}\Omega \end{aligned}$$

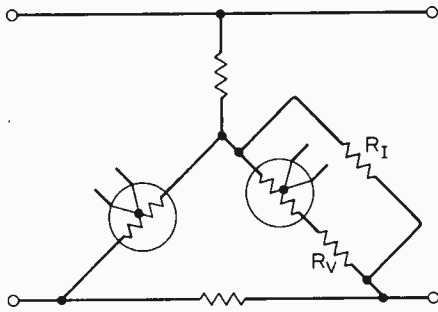

Fig. 3. Matching thermocouples.  $R_v$  is chosen to balance thermocouple outputs when only a voltage is applied  $R_1$  is then added to balance the thermocouples outputs when only a current flows.

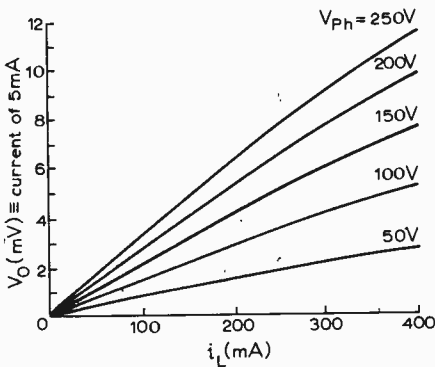

Fig. 4. Characteristic of the thermocouple multiplier when using the full current range 0 to 5mA. The device underreads by about 12% at f.s.d.

Half the current flowing through the vacuum thermocouple must be proportional to the mains voltage, and the other half proportional to the load current.

For a maximum thermocouple current of 2.5mA,

$$i_1 \text{ max} = 2.5\text{mA}$$

contributing 1.25mA to each thermocouple. Hence, the minimum mains voltage required is

$$V_{ph} \text{ min} = R_1 \text{ min} \times i_1 \text{ max} = 100\text{V.}$$

The maximum voltage to appear across  $R_3$  is

$$V_{R3} \text{ max} = 1.25\text{mA} (400\Omega + 400\Omega) = 1\text{V}$$

This is the voltage due to a load current alone, i.e.  $R_1$  is an open circuit.

Similarly, the minimum load current that can be measured is

$$i_L \text{ min} = \frac{V_{R3} \text{ max}}{R_3 \text{ max}} = \frac{1\text{V}}{4\Omega} = 250\text{mA}$$

Normally, it will be found that the thermocouples are not identical, e.g. their heater resistances are not the same and hence their characteristics are not the same. Thermocouples may be matched by adding two resistors as shown in Fig. 3. Resistance  $R_v$  is chosen to balance the thermocouple outputs when only a voltage is applied to the multiplying circuit;  $R_1$  is then added to balance the thermocouple outputs when only a current flows.

Fig. 1. shows the characteristic of a

thermocouple on a double logarithmic scale. The practical line has a slope of 1:1.9 as compared to 1:2 of the ideal line. The error due to the non-ideal square law characteristic can be minimized by utilising the lower portion of the characteristics only.

Fig. 4 shows the characteristic of a thermocouple multiplier using the full current range of the device; in this particular case 0 to 5mA.

It can be seen that the equipment underreads by about 12% at f.s.d. Reducing the multiplier output to 3mV and amplifying this signal to drive 1mA moving-coil meter, the characteristics shown in Fig. 5 were plotted. The error is now about 1% at f.s.d.

### Vacuum thermocouple amplifier

The thermocouple multiplier output is insulated from the supply line and is therefore easily connected to an amplifier. The amplifier shown in Fig. 6 drives a 1mA meter calibrated in watts. The current through the instrument is given by:

$$I_{out} = \frac{V_i}{R_3} \times \frac{R_2}{R_1}$$

The thermocouple multiplier forms an integral part of the supply line. Since it is purely resistive the multiplier will work on any supply voltage and take account of the phase angle between voltage and current. For large load currents the upper limit for multiplication depends on the power dissipated in resistor  $R_3$ . In order to overcome this difficulty two methods can be adopted: the resistor  $R_3$  can be replaced by a current transformer or a transformer can be connected across a suitable low ohmic resistor.

For domestic purposes the first technique will be used, as shown in Fig. 7(a). The voltage across the secondaries of the transformer is proportional to the current through the primary winding. A connection between the primary and secondary windings of the transformer is required to allow the current flow due to the supply voltage. It should be pointed out that due to the non availability of a suitable current transformer the final circuit constructed was as shown in Fig. 7(b). An ordinary voltage transformer with a split secondary winding was used. The turns ratio between the primary and the total secondary was 1:46. The resistance  $R_3$  consisted of a 30cm length of copper wire, 1mm thick. Clearly, the range and overload properties of this circuit depend on the resistor and can easily be changed.

### Watt to Watt-hour conversion

Since energy is the time integral of power, the addition of a suitable integrator widens the range of application of a multiplier. Although an active integrator has a larger range of integration than a passive one both circuits have the disadvantage that the capacitors will eventually be charged and integration cease. In an active integrator, the output voltage attains the same value as the supply voltage.

The circuit in Fig. 8 overcomes this limitation by sensing the integrator voltage with another amplifier before limiting occurs and at the same time passes a pulse to a digital counter. The counter acts as a store and its total pulse count represents watt-

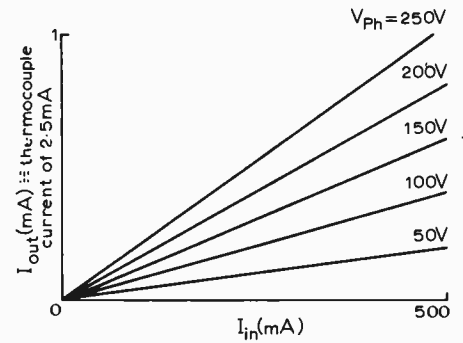

Fig. 5. Reducing the output of the multiplier to 3mV, and using an amplifier, reduces the error to 1% at f.s.d.

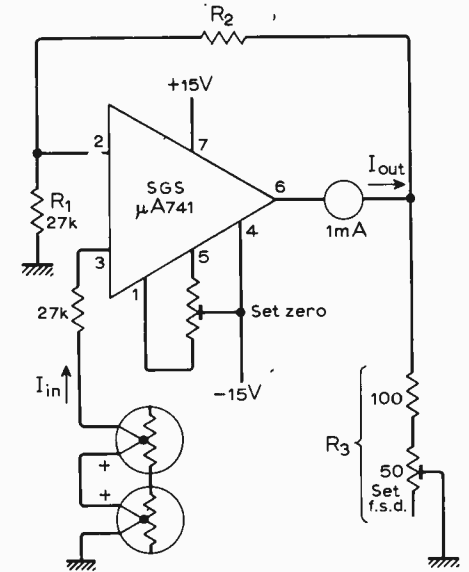

Fig. 6. Thermocouple amplifier circuit.

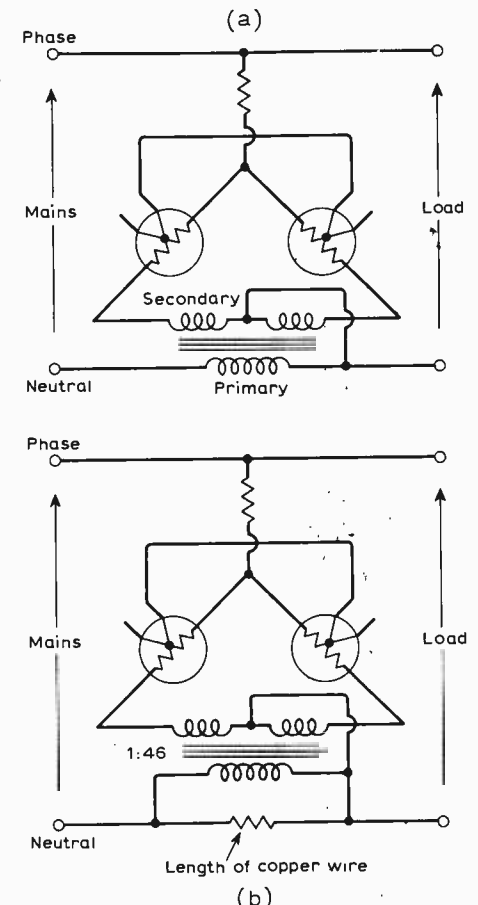

Fig. 7. Using a current transformer (a), and a voltage transformer (b).

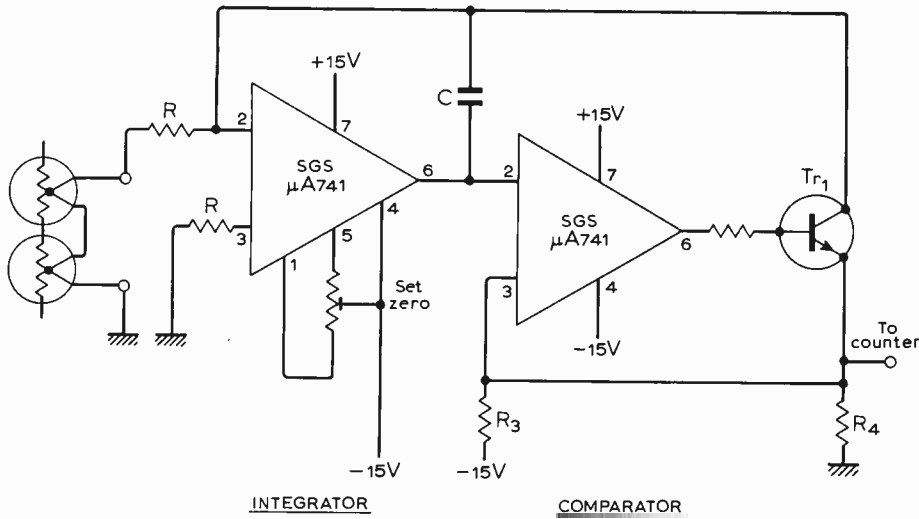

Fig. 8. Integrator circuit to drive a counter calibrated in Wh.

hours. The potential divider  $R_3$  and  $R_4$  determines the reset voltage. As the output of the integrator reaches this voltage, the comparator drives  $Tr_1$  into saturation. Positive feedback is applied to the non-inverting input of the comparator which rises to 0V,  $C$  is discharged via  $Tr_1$  until the integrator reaches 0V. At this point the comparator output voltage falls and  $Tr_1$  is turned off. This process is now repeated.

The output pulses are fed into a monostable multivibrator, which operates an electromagnetic counter.

The described multiplier circuit could also be used for a variety of other purposes:

- To measure the power consumed in a loudspeaker, since it represents a reactive load and the audio frequency is a complex waveform.
- To measure the power supplied to an a.c.

motor working with an s.c.r. speed control (also light dimmer).

- To measure the power supplied to high-frequency systems.

**Thermocouple data**

Heater current range 5mA; maximum overload 7.5mA; heater resistance 400Ω; couple resistance 2Ω, couple output 12–15mV o.c.

Thermocouple obtainable from Ormandy & Stollery, 3 Victoria Place, Brightlingsea, Essex.

**Preliminary specification**

- Supply voltage—±15V, 50mA max.
- Input main voltage—≥100V for f.s.d.
- Input line current—≥250mA for f.s.d.
- Accuracy—1% of f.s.d.
- Temperature drift—0.2% of f.s.d./°C
- Bandwidth—d.c. to 100MHz
- Selected resolution—1 digit = 10Wh.

**Acknowledgements**

The author is indebted to Mr. C. R. Harris, who conducted much of the experimentation and obtained the results on which this article is based. Acknowledgements are made to Dr. J. L. Clark, Head of the Department of Physics & Physical Electronics, Newcastle-upon-Tyne Polytechnic, for placing the facilities of his department at the author's disposal.

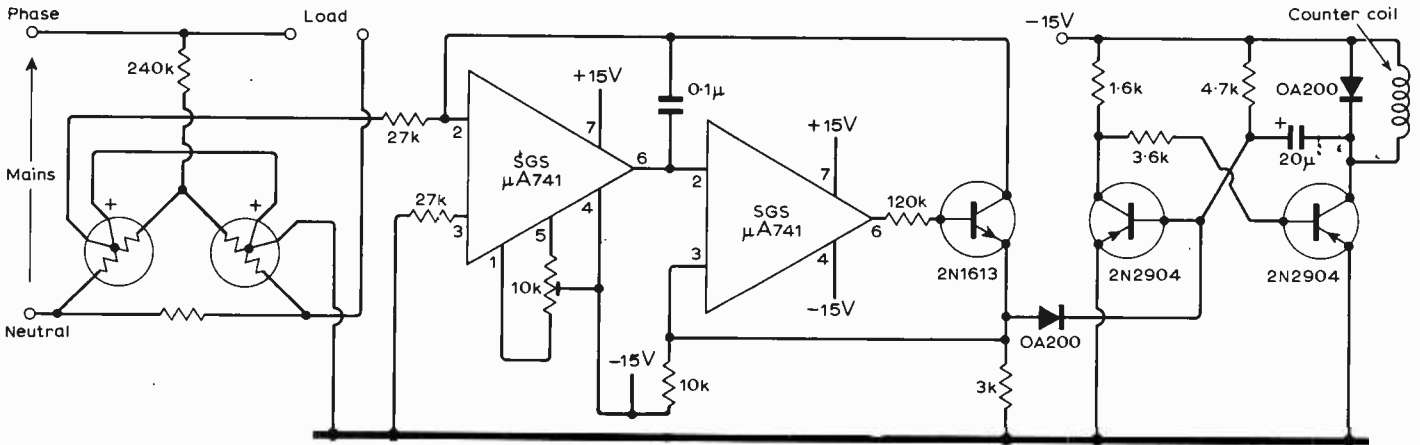

Fig. 9. The complete electricity meter. Note that this employs the resistor  $R_3$  of Fig. 2; if desired one of the transformer versions of Fig. 7 may be used.

## Communications Conference and Exhibition

As already announced, a conference on radio and data communications is to be held at the Metropole Convention Centre, Brighton, from 13th-15th June in conjunction with the Communication 72 exhibition. The conference, organized by *Electronics Weekly* and *Wireless World*, will comprise three parallel sessions on each of the three days, with probably four papers per session. Evening discussion meetings are also being planned. The primary aim will be to appeal to communications users.

Papers are invited from industry, government departments, the armed services, universities etc, relating to both civil and military applications in the areas listed.

In the first instance, authors should submit summaries of 200-300 words, describing the subject and scope of the paper, by 3rd January to The Editor, *Electronics Weekly*, Dorset House, Stamford

Street, London, S.E.1. Speakers will be notified of acceptance by 7th February.

Suggested topics include — *Radio communications*: satellites; earth stations; microwave systems; advanced transmitter and receiver circuit techniques; propagation; diversity; scatter; aerials etc. *Data communications*: national data grid; data compatibility; modems; data concentrators; minicomputers for control and processing of messages. *Mobile & point-to-point radio systems*: selective calling; facsimile; teleprinters; frequency allocations and channel spacing. *Recording equipment*: digital and analogue recording techniques; retrieval of recorded information. *Test equipment*: signal generators; spectrum analysers; noise measuring equipment; automated test equipment etc. *New component developments*.

# Low-impedance Microphone Pre-amplifier

## Low noise design using an integrated circuit

by J. M. Howells\* and J. R. Jones\*

Traditionally one of the most difficult audio circuits to design has been the pre-amplifier for a low-impedance microphone, either ribbon or moving-coil, due entirely to the very small signals it generates. The smallest sound pressures likely to be encountered in practice will be about 70dB, the pressure† from speech at 30cm. Microphone data sheets give the output from such a level as between 100 and 150  $\mu\text{V}$  from a 200-ohm source. It is common practice, however, to design for a 600-ohm source, since this is the highest impedance likely to be met.

The problem is put into perspective by noting that the Johnson, or thermal, noise from a 600-ohm resistor is 441nV and that from a 200-ohm resistor is 262nV over a 20kHz noise bandwidth. This means that, even if the amplifier itself generates no noise, the signal-to-noise ratio obtainable will typically be only 54dB. In comparison, the output from even the most insensitive of modern high-quality magnetic pickups is unlikely to be less than 4mV when tracking a record with average modulation, requiring an input noise of 4 $\mu\text{V}$  to give a 60dB signal-to-noise ratio. Similarly, a low output tape head giving 2mV from a tape recorded to 32mM/mm will require 2 $\mu\text{V}$  of noise to give the same signal-to-noise ratio. Noise performance of this order can easily be obtained from discrete amplifiers, using bipolar transistors, biased as in the literature<sup>1,2</sup>.

For any amplifier there is an optimum resistance which gives the lowest noise figure, and this is readily calculated. Knowing the source resistance the designer of a discrete component amplifier can tailor his design to give the optimum noise performance. An alternative technique is to match the source resistance to the optimum for the amplifier by using a transformer. The designer using an i.c. is constrained to use this last-mentioned technique since the currents in the input stage, and therefore the optimum source resistance, are fixed.

Provided that the optimum source resistance for the amplifier is not too much larger than the source resistance, the transformer will perform the dual role of noise resistance matching and accepting a balanced input. The balanced input is desirable because it gives the maximum

rejection of extraneous hum and noise pick-up, particularly important when long cables are used. The optimum source resistance must not be too much larger than the actual source resistance, otherwise the high impedance secondary will cause a loss of treble, and will itself be more sensitive to hum pick-up.

As well as amplifying the low-level signal quoted previously without adding significant noise, the pre-amplifier is also required to handle the output from an orchestral climax, which might reach 110dB. This will give a signal of up to 15mV, and will require an output of several volts from the amplifier, without serious distortion. When sound levels even higher than this are met, they can be dealt with by inserting a resistive attenuator between the microphone and the amplifier, since noise has now ceased to be an important consideration.

A flat frequency response in the audio range is essential. Further, a low output impedance is desirable, allowing a reasonable length of cable to be used at the output without loss of treble, and also permitting the use, without significant loading, of the 5k $\Omega$  and 10k $\Omega$  slide faders now available.

It is widely accepted that integrated circuit amplifiers are noisier than their discrete counterparts, but there are some low noise i.c.s available at very competitive prices. One example is the Fairchild  $\mu\text{A739}$  dual low-noise operational amplifier (now re-numbered as U6E 7739 393), available for £1.68, which is also available as the SGS TBA 231 at £1.80, both being encapsulated in 14-pin d.i.l. packages.

The noise performance of these amplifiers

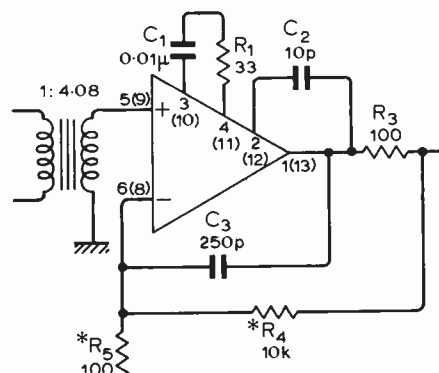

Fig. 1. Single channel of amplifier.

is quoted in some detail, both on the data sheets and on a Fairchild application note. From the data sheet figures of 5nV/Hz and 0.5pA/Hz at 10kHz the optimum source resistance is found to be 10k $\Omega$  ( $R_{opt} = e_n/i_n$ ). Transformers with an impedance ratio of 600 $\Omega$ :10k $\Omega$  are easily obtainable, the one used in the authors' prototype being a Gardners type MU7526. This is quoted as having a response within 0.5dB from 30Hz to 20kHz, and will handle levels up to +12dBm. A cheaper alternative is the Gardners VM7466 having a quoted response of 0.5dB down at 50Hz and 15Hz and 1.0dB down at 30Hz and 22kHz. This latter transformer should satisfy all but the most stringent requirements.

An analysis of the noise performance of the configuration in Fig. 1 is given in the Appendix and shows that it meets the required noise performance, as well as meeting all the other requirements.

Components  $R_1$ ,  $C_1$  and  $C_2$  compensate the amplifier for unity gain. The 100- $\Omega$  resistor  $R_3$ , in series with the output, is explained as follows. When a capacitive load on an integrated circuit amplifier is much greater than 100pF, some consideration must be given to its effect on stability. Stability is ensured by using the configuration shown, the technique being described by Widlar.<sup>3</sup> The capacitive load is isolated from the op-amp by the 100- $\Omega$  resistor. At high frequencies the feedback path is through the lead capacitor  $C_3$  whose value is not critical, and is chosen in this instance to give a good square wave response at 10kHz. It is essential, using this technique, that the amplifier be compensated for unity gain.

In the circuit of Fig. 1 the  $\mu\text{A739}$  is capable of giving an output of 7.25V r.m.s. before clipping, which represents a level of +19.4dBm. The optimum level for audio signal mixing between overload and noise is about 150mV, requiring an output of 300mV from the pre-amplifier when 6dB of reserve gain is held on the fader. A gain of 52.2dB, obtained by taking a gain of 40dB out of the amplifier, raises a signal of 500 $\mu\text{V}$  to 244mV, which is of the right order of magnitude. This represents a sound pressure of greater than 85dBA. The signal of 15mV from a peak level will now be raised to 6.1 volts, well within the capabilities of the amplifier. Although 52dB is a reasonable compromise between gain and overload the amplifier may be set up for a different gain by changing the value of  $R_5$ , which should be a low noise component, preferably metal film (see Appendix). The value of  $R_4$  should not be decreased, since the increased load on the output will lower the overload point.

Performance tests were carried out on five samples of the integrated circuits, three type TBA 231 and two type  $\mu\text{A739}$ . There was no significant difference in the measured performance of the amplifiers from the two manufacturers.

The noise performance was measured using a 619- $\Omega$  metal film resistor as the source, over a noise bandwidth of 20kHz. In only one case was the noise performance worse than 2dB, then reaching 2.35dB. A noise figure of 2dB from a 600- $\Omega$  source

\*Plessey Telecommunications Ltd. †Siliconix Ltd.  
‡Reference: 0.0002 dyn/cm<sup>2</sup>.

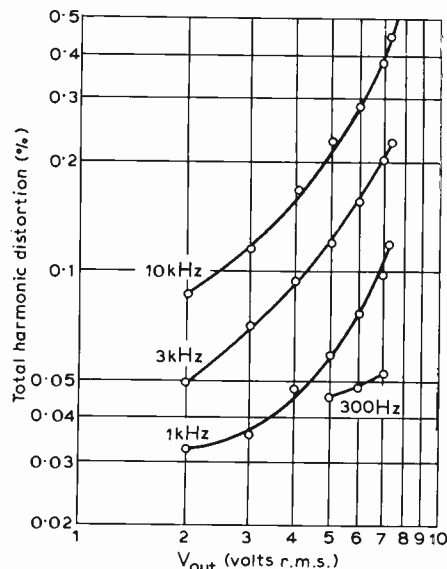

Fig. 2. Total harmonic distortion of amplifier at four frequencies.

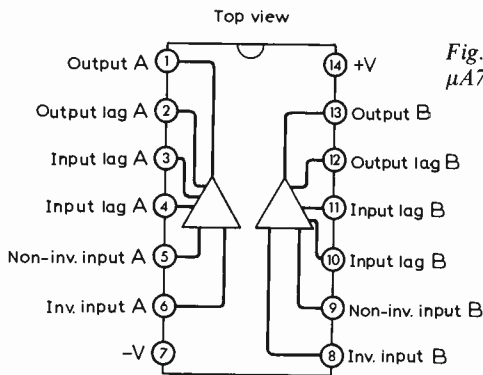

Fig. 3. Connections of the μA739 integrated circuit.

requires an input of about 500μV for a signal-to-noise ratio of 60dB. This signal is approximately that which would be obtained from a sound pressure of 80dB, and it is likely that the ambient noise will be at least 10dB above the noise level of the amplifier in all but the quietest studios. No resistor has been used across the transformer, as is usual to ensure correct loading, as this would impair the signal-to-noise ratio. The frequency response of the amplifier/transformer combination is 1dB down at 12Hz and 57kHz, using a MU7526, and a 10kHz square wave shows only a slight ring at about 160kHz. The performance on 1kHz and 100Hz square waves is excellent, with only a small tilt observable on the latter.

The total harmonic distortion was measured using a Radford distortion measuring set and a filtered, battery-powered, oscillator, and is shown in Fig. 2 for four frequencies. The residual, after removal of the fundamental, was displayed on a scope, as well as being examined using a Marconi wave analyzer. These showed the distortion to be almost entirely second harmonic, and to be decreasing at lower outputs, where hum and noise made direct measurements difficult. This decrease with output is to be expected, because the μA739 has a single-ended class A output stage.

The authors' prototype was assembled on a printed board, though this is not necessary, and was run from 15V supplies.

For use on a single-ended supply it is only necessary to take the earth point to the junction of two 10kΩ resistors bridging the supply, and to decouple this point to earth using a 100μF capacitor. If a single-ended supply is used, an output capacitor of about 10μF will be needed. Low-noise metal oxide or preferably metal film resistors should be used for R<sub>4</sub> and R<sub>5</sub>. Connections of the i.c. are shown in Fig. 3.

Work on the amplifier and testing were done at University College, Swansea.

**Appendix**

The equivalent circuit for Fig. 1 for noise calculations is shown in Fig. 4. This is further simplified by transferring all the voltage sources and resistances to the transformer secondary and taking *i<sub>n</sub>* as being equal to *i<sub>n</sub><sup>+</sup>*. This is reasonable because the same configuration is used to measure *i<sub>n</sub>* except that a large resistor is connected across the non-inverting input and ground in place of the transformer.

$$\text{Since } i_n^- \left( \frac{R_5 R_4}{R_5 + R_4} \right) \ll i_n^+ R_9, \text{ } i_n^- \text{ is neglected.}$$

The transformer Barkhausen noise is also negligible.

Thus in Fig. 5 the noise voltage source consists of the source resistor Johnson noise, the transformer primary and secondary resistances' noise, the amplifier noise voltage generator and the noise voltage

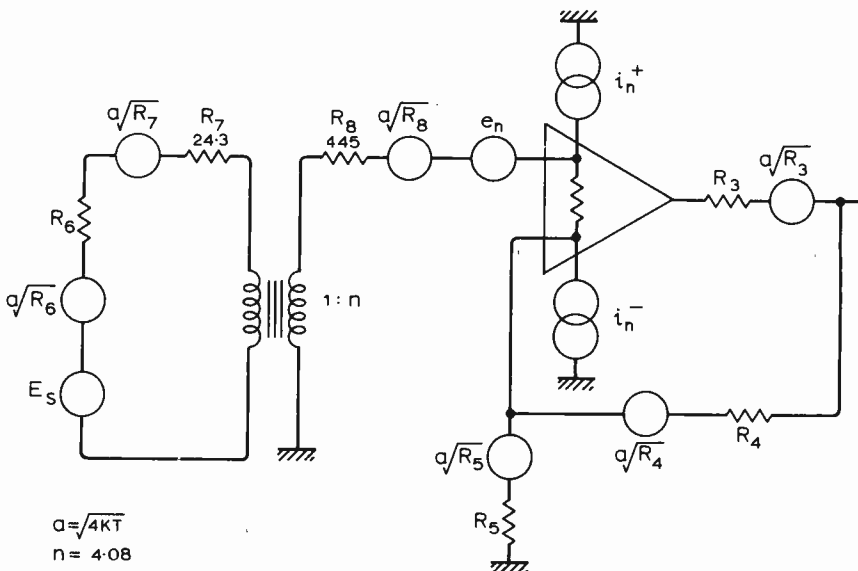
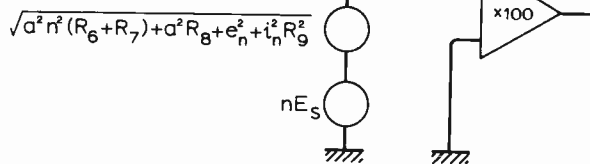

Fig. 4. Equivalent circuit showing noise sources.

Fig. 5. Simplified diagram for noise calculation.



generated by the amplifier current noise flowing through the total resistance in the transformer secondary. This voltage source is in series with an equivalent resistance R<sub>9</sub>. The amplifier is approximated by a noiseless, infinite input impedance amplifier with a gain of 100.

Substituting values of

$$R_6 = 619\Omega, R_7 = 24.3\Omega, R_8 = 445\Omega$$

$$e_n = 5nV/\sqrt{\text{Hz}}$$

$$i_n = 0.5pA/\sqrt{\text{Hz}}$$

$$V_o = 100 \sqrt{a^2 n^2 (R_6 + R_7) + a^2 R_8 + e_n^2 + i_n^2 R_9^2}$$

$$V_o = 100 \times 15.5nV/\sqrt{\text{Hz}}$$

$$\therefore \text{Noise referred to transformer primary} = 3.8nV/\sqrt{\text{Hz}}$$

$$\text{Noise factor} = \frac{V_{\text{no total}}^2}{V_{\text{nRS}}^2}$$

$$= \left( \frac{3.8}{3.18} \right)^2 = 1.43$$

$$\text{Noise figure} = 10 \log_{10} \text{noise factor} = 1.55\text{dB}$$

**References**

1. Faulkner, E. A., 'The Design of Low-noise Audio-frequency Amplifiers', *The Radio & Electronic Engineer*, July 1968, pp. 17-30.
2. Watson, J., 'Semiconductor Circuit Design', Adam Hilger, 1971.
3. Eimbinder, J. (éd.), 'Designing with Linear Integrated Circuits', John Wiley, 1968, p. 29.

# Linear Frequency Meter

## Two-decade per range frequency-to-voltage converter can go down to 0.1Hz and up to 100kHz

by D. Anderson\*

This article describes a linear frequency-to-amplitude converter, covering the range 1Hz to 100kHz in switched ranges. Although developed primarily for use with nuclear physics equipment, its field of use is much wider, and with the component changes described at the end of the article it is particularly suited to medical electronics applications.

The instrument displays, on a moving-coil meter, the repetition rate of incoming pulses whose amplitude and shape are non-critical. The repetition-rate for meter f.s.d. is in switched ranges, and control of the time-constant of readout is provided. Power supplies required are +12 and -6 volts, both of which should be stabilized.

Alternative approaches to the problem were considered, and useful resumés of these, and bibliographies, are contained in papers by Neilson,<sup>1</sup> whose emphasis is on their application to medical electronics, and especially by Waddington who treats circuit design in greater depth.<sup>2</sup>

The simple diode pump was tried initially, and a logarithmic output was obtained over a frequency range of almost a decade. Deviation from the logarithmic relationship between frequency and output voltage could be partially corrected at the upper

end of the decade by inclusion of a suitable variable capacitance diode in series with the pump input capacitor.

Complete correction of the characteristic to a logarithmic law was not achieved, and attention was then given to the diode-

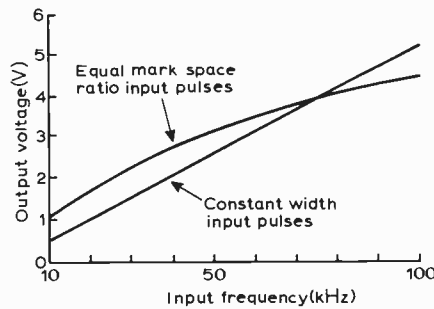

Fig. 1. Transfer characteristics of diode-transistor pump showing better linearity when fed with constant-width pulses than when fed with equal mark-space pulses.

transistor pump. This was found to be a more promising approach, and development of this circuit has yielded an instrument with a linear conversion of frequency to voltage over at least two decades per range.

To achieve this linearity, it is necessary to drive the pump with pulses of constant width and amplitude. The effect of using a pulse train of constant mark-to-space ratio is to introduce non-linearity to the pump characteristic, as shown in Fig. 1.

The specification for the complete instrument is given in the table (next page).

### Circuit description

The input signal, which can be of unspecified shape, is converted to rectangular pulses by a comparator to provide constant-amplitude trigger pulses for a constant-width pulse generator, see Fig. 2. The pulse amplitude is stabilized by an amplifier before the pulses are fed to the pump circuit. The pump output is arranged to have a short time constant, and the succeeding stage allows an extension of this time. The pump and



Fig. 2. Input signal is processed to feed constant-amplitude and constant-width pulses to the diode-transistor pump.

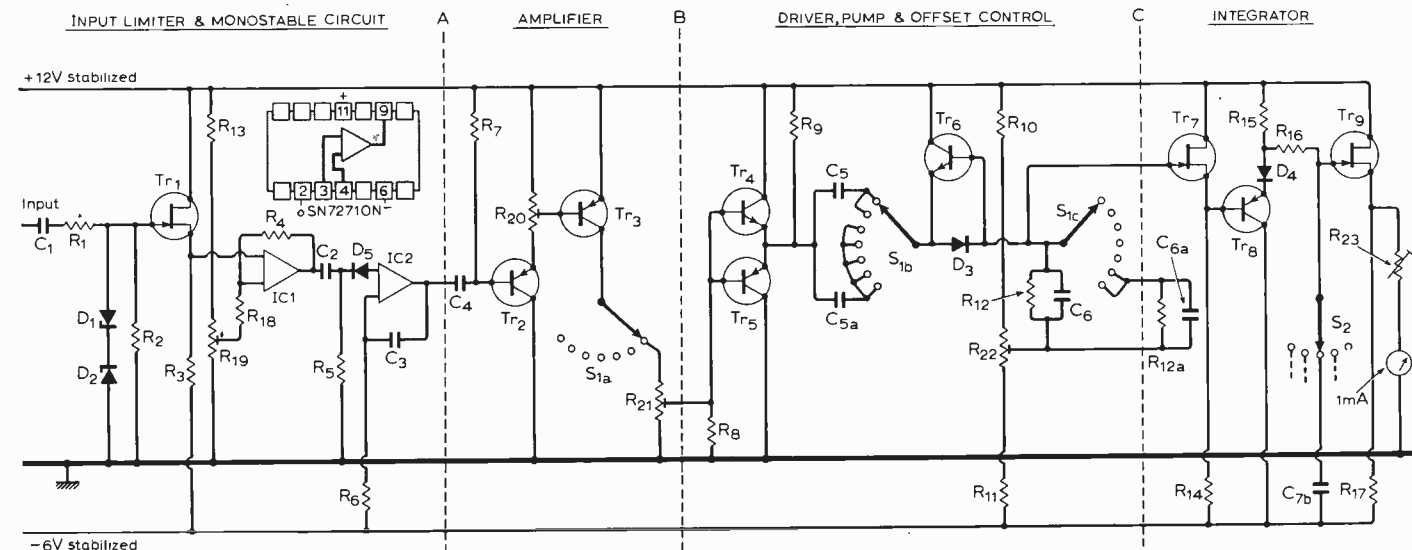

Fig. 3. Complete circuit of frequency meter, with seven (overlapping) ranges having f.s.ds from 100Hz to 100kHz.

time constant stages are followed by f.e.t.s to minimize loading. The output is taken from a source follower with a  $Z_o$  of 400Ω.

The width of the pump input pulse is chosen to be a working compromise over the whole frequency range, and is 2μs. Ideally, one should increase pulse width as the counting rate is decreased, and this could be a useful modification to the present instrument (see Fig. 5b).

The basic input stage comprises the comparator and pulse generator, shown to left of line A in Fig. 3. Transistor  $Tr_1$  presents a high input impedance to the applied signal. The 1-MΩ gate shunt resistor  $R_2$  is in parallel with two back-to-back zener diodes which restrict the gate voltage swing to ±3.9V as a measure of protection for the input stages. The series resistor  $R_1$  determines the input impedance during overload.

The input signal is amplified by comparator  $IC_1$ , and the output differentiated to trigger the monostable circuit,  $IC_2$ . By adjusting the d.c. level at  $IC_1$  input, the 2-μs output pulse can be made independent of input signal amplitude and frequency. The pulse width is approximately  $0.7R_6C_3$ . Buffer transistor  $Tr_2$  presents a high impedance to  $IC_2$ , and allows control of base drive to  $Tr_3$  by  $R_{20}$ . This allows  $Tr_3$  to produce a consistently sharp-rise  $V_{CE(sat)}$  collector pulse at all repetition rates. The pulse is developed across a series of switched 1-kΩ potentiometers, and an appropriate pick-off voltage is selected to each frequency range.

Collector pulse amplitude of  $Tr_3$  is held constant by choosing a suitable component for  $Tr_3$ , having a  $V_{CE(sat)}$  which is relatively independent of temperature and collector current over the narrow range involved in this circuit (Fig. 4) and by using a stabilized supply line. The importance of maintaining

**Instrument specification**

frequency ranges for f.s.d.	100, 300Hz; 1, 3, 10, 30, 100kHz
output voltage for f.s.d.	6V
zero offset	adjustable to <20mV
output time constants	0.3, 1, 3, 10, 30s
input voltage	100mV to 20V
input impedance	1MΩ (470kΩ for V in >3V)
output impedance	400Ω

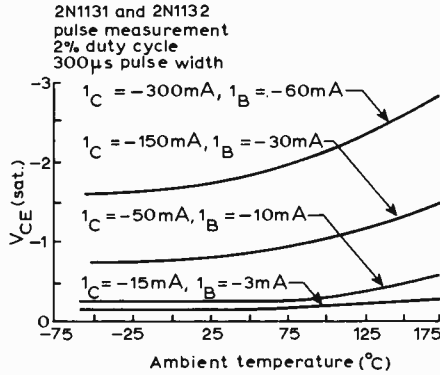
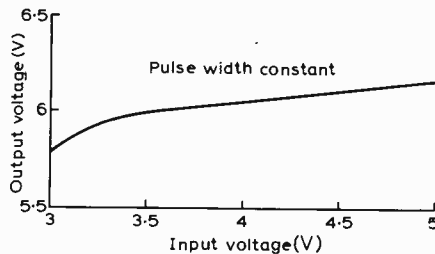
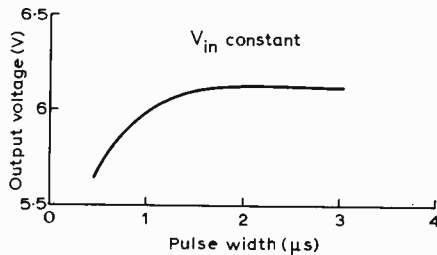

Fig. 4. Pulse amplitude at  $Tr_3$  collector is held constant by using a transistor with a  $V_{CE(sat)}$  relatively independent of temperature and collector current.



(a)



(b)

Fig. 5. Pump characteristics for constant pulse width (a) and for constant pulse amplitude (b) show importance of maintaining constancy.

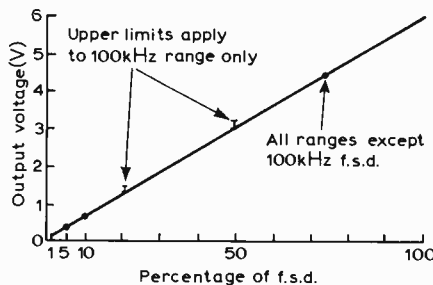

Fig. 6. Linearity of completed instrument—straight line applies to ranges below 100kHz f.s.d. and upper limits shown at 10, 20 and 50% f.s.d. refer to 100kHz range.

a constant pulse amplitude can be seen from Fig. 5(a).

The theory of the diode-transistor pump has been developed in Waddington's article and elsewhere, and we will refer to only one of the equations here

$$V_o = fC_5R_{12}V_i$$

In the present application of the pump, covering 1Hz to 100kHz, range-changing requires that both  $C_5$  and  $R_{12}$  are changed. The maximum value of  $R_{12}$  is determined by the tolerable shunting effect of succeeding circuitry, and the minimum value by the required sensitivity, as is the minimum value of  $C_5$ . The maximum value of this capacitor is limited by the charging energy available in the pump input pulse, and to maintain sufficient energy over the whole frequency range of the instrument, a complementary emitter-follower is included between the pulse-shaping amplifier and the pump, shown between lines B and C in Fig. 3.

As an output time-constant switch for alternative times is required, it was useful to arrange that  $R_{12}C_5$  yields the minimum time constant required.

The pump output is fed to a simple integrator to provide longer output time constants as required, shown right of line C in Fig. 3.

The pump and integrator are buffered by source followers. The integrator time constant is determined by  $R_{16}$  and  $C_7$ , and this capacitor must be a low-leakage type; diode  $D_4$  compensates for the small magnitude of  $C_7$  leakage current. The 100-kΩ pre-set resistor  $R_{23}$  in series with the meter allows f.s.d. adjustment.

To adjust the no-signal d.c. level at the output of the integrator, the  $C_6, R_{12}$  combination is returned to an adjustable d.c. level.

Due to dependence of the output on the supply voltages, the positive line for sensitivity, and the negative line for d.c. level at the output, stable supply voltages are required.

**Setting up**

- Set time-constant switch to 330ms, frequency range switch to 100kHz, and connect supplies.
- Adjust  $R_{22}$  to give zero volts d.c. at output.
- Apply 100kHz sine wave input and adjust  $R_{19}$  for symmetrical mark-space switching at  $IC_1$  output.
- Adjust  $R_{20}$  to give square pulse at  $Tr_3$  collector.
- Adjust  $R_{21}$  to give an output of 6V, and similarly adjust corresponding presets on other ranges.
- Adjust  $R_{23}$  to give f.s.d. on meter.

The instrument is now set up, and an example of input/output characteristics from one of the prototypes is shown in Fig. 6.

**Range extension**

Having met the specification laid down for the original application, the circuit was investigated for use at lower frequencies, which would be useful in medical electronics.

By changing the values of the components as shown in Fig. 7, and using a pulse width

**Components list**

Resistors			
	3	470p	
	4	390p	
1	470k	5	6n
2	1M	5A	120p
3	10k	6	47n
4	100k	6A	0.47μ
5	22k	7	10μ (τ = 30s)
6	3.9k	7A	3.3μ (τ = 10s)
7	100k	7B	1μ (τ = 3s)
8	47k	7C	0.33μ (τ = 1s)
9	4.7k		
10	1k		
11	1k		
12	4.7M	Active devices	
12A	470k		
13	470	Integrated circuits	
14	5.6k	SN72710N	
15	4.7k	Transistors	
16	3.3M	1	2N3819
17	5.6k	2	2N3702
18	1k	3	2N1131
19	500	4	2N697
20	10k	5	2N1131
21	1k*	6	2N390
22	1k	7	2N3819
23	100k	8	2N722
		9	2N3819
Capacitors		Diodes	
		1, 2	3.9V zeners
1	0.68μ	3	1N914A
2	15p	4, 5	1N914

\* One for each range.

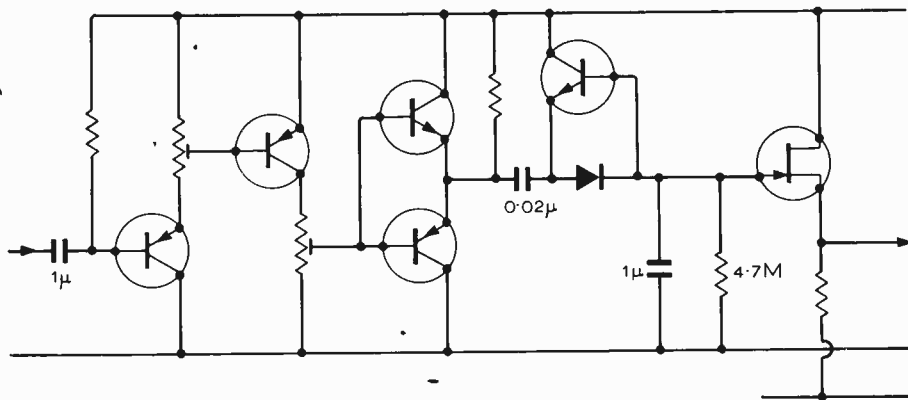

Fig. 7. To extend bottom of range down to 0.1Hz, change components as shown.

of 250 $\mu$ s, a linear conversion has been verified over the range 0.1Hz to 100Hz. The 10- $\mu$ F pump output capacitor must be low leakage, otherwise linearity will be affected.

Extending the low-frequency range of this simple pump circuit would require a larger time constant than the present one, of 100 $\mu$ F  $\times$  4.7M $\Omega$ , in the interests of having a reasonably smoothed output. One can either do this by increasing the capacitance value with a considerable increase in cost, or one can increase the value of  $R$ , presently 4.7M $\Omega$ , with a possible increase in non-linearity, due to current leakage through the source-follower gate.

A further complication would arise from increasing the output capacitor—to obtain f.s.d. from a range one decade lower (0.01 to 1Hz) would require that the pump sensi-

tivity be increased by a factor of 10, i.e. the 0.02- $\mu$ F capacitor would be 0.2 $\mu$ F, and an excessive demand would be made on the complementary emitter follower. This area of operation has not, however, been investigated so far.

At the other end of the frequency range the circuit has been proven up to 1MHz.

### References

1. Neilson, J. M., European Symposium of Medical Electronics (Official Proceedings) 1965, p. 274.
2. Waddington, D. E. O'N., 'Diode-transistor pump', *Wireless World*, vol. 72 1966, p. 338-42.
- Towers, T. D., 'Elements of transistor pulse circuits', *Wireless World*, vol. 70 1964, p. 403-7.

## Sixty Years Ago

January 1912. A method for measuring condenser losses by comparing the component under test with a "non-dissipative" air condenser was given by J. A. Fleming in *The Marconigraph*. The necessary arrangement (Fig. 1) is set up so that a steady current is produced in the secondary coil which is very loosely coupled with a primary generating coil. "This continuous current then gives us the root-mean-square value of any high-frequency current, which . . . gives the same deflection on the galvanometer as the direct current. . . ."

"The condenser under test,  $C$ , may be considered to have its energy-dissipating power represented by a certain internal

resistance which we will call  $r$ , which is in series with a capacity equal to the true condenser capacity. . . ."

"The process of measurement is as follows. First, oscillations are set up in the primary circuit by means of the induction coil, and the secondary circuit is adjusted in such loose coupling that there are in it oscillations of only one frequency. . . . We then insert the condenser,  $C$ , in the secondary circuit and vary the capacity,  $C_2$ , and also that in the primary circuit until the two circuits are in tune and the frequency,  $n$ , has any desired value. Then observe the current,  $A$ , as read on the hot-wire ammeter.

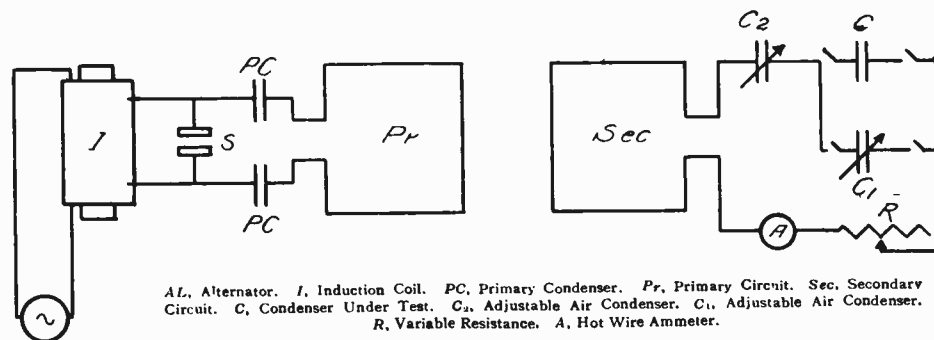

A.L., Alternator. I, Induction Coil. PC, Primary Condenser. Pr, Primary Circuit. Sec, Secondary Circuit. C, Condenser Under Test. C<sub>2</sub>, Adjustable Air Condenser. C<sub>1</sub>, Adjustable Air Condenser. R, Variable Resistance. A, Hot Wire Ammeter.

"Next substitute for the given condenser,  $C$ , the movable-plate air condenser,  $C_1$ , and vary its capacity until the current,  $A$ , has a maximum value. Also, vary the sliding resistance,  $R$ , until the current has the same value. . . ."

"We have then substituted for the capacity of the condenser under test the equal capacity of a non-dissipative air condenser, and for the internal resistance or source of energy dissipation in the first condenser we have substituted an external resistance,  $R$ , and have the same current in the two cases and the same frequency. Hence the decrement must be the same. Therefore the energy loss in the condenser,  $C$ , is given by the value of  $A^2R$  where  $A^2$  is the mean-square condenser current and  $R$  is the external resistance."

## Announcements

Found loose in the post — a copy of the June 1971 issue of *Wireless World* stamped A.R.A. Library. Apply to the Editor.

The Council of the **British Tape Industry Association**, formed to cover the interests of manufacturers and suppliers of blank tape, recorded tape, tape hardware and accessories and ancillary equipment, has recently held its first meeting at which Philip Ashworth, of Musitapes (Wholesale) Ltd, was appointed chairman and R. Bishop, of Metrosound Audio Products Ltd, vice-chairman.

**Laser systems** is the title of a short course of lectures to be held at Norwood Technical College each Tuesday evening for six weeks, commencing 8th February. Further details from the Senior Administrative Officer, Norwood Technical College, Knight's Hill, London SE27 OTX. Fee £2.

Jermyn Distribution announce a **cash sale 'by-return' service** enabling the professional engineer who is also a hobbyist to obtain Motorola, General Electric, Raytheon and Jermyn's own products direct from them.

**Unitech-Pantiya**. — The offer of Unitech Ltd, to acquire all the issued shares of Pantiya Electronics Ltd, not already owned by them, has been accepted.

The name of **Aveley Electric Ltd**, of South Ockendon, Essex, has been added to the approved list of companies which are acceptable to the Air Registration Board for test equipment re-certification.

M.C.P. Electronics Ltd., Alperton, Wembley, Middx. HAO 4PE, have been appointed sole U.K. representatives for **Globe Industries Inc.**, a division of TRW, of Dayton, Ohio, U.S.A.

Mimic Diagrams & Electronics Ltd., Maxim Road, Crayford, Kent, have recently changed the name of the company to **Mimic Electronics Ltd.**

3M Company, of Minnesota, and Sony Corporation, of Tokyo, have entered into a **cross-patent licence agreement** which will permit Sony to manufacture and sell 3M high-energy magnetic tape and 3M to manufacture and sell Sony  $\frac{1}{2}$ in U-matic videocassette equipment.

EMI Electronics Ltd, Hayes, Middx, have signed an agreement with Disa Elektronik A/S, of Herlev, Denmark, whereby Disa will transfer all know-how and rights for further development and production of a range of monochrome and colour **television monitors** to EMI. Disa have been appointed representatives for sales and service in all Scandinavian countries for EMI television picture monitors.



# Temperature Stabilization of Oscillators

## How to take guesswork out of compensation

by D. A. Tong, B.Sc., Ph.D. (G8ENN)

The most serious cause of frequency drift in variable frequency oscillators is undoubtedly the effect of changes in ambient temperature, especially now that good voltage stabilization is so easily achievable. To eliminate such temperature effects it is necessary to select a correct combination of components with positive and negative temperature coefficients so that the overall temperature coefficient of frequency is as close to zero as required by the particular application.

By trial and error this can be a very tedious process because of the appreciable time taken by the complete oscillator circuit to attain thermal equilibrium after each change in the conditions. This article shows how, by the use of a little arithmetic, the process of adjustment can be made far more straightforward and less time consuming. Using published data for the temperature coefficients of the capacitors used in the tank circuit together with one measurement of the temperature coefficient of the complete oscillator circuit it is possible, using three equations derived in the appendix, to calculate what combination of capacitors would result in a zero temperature coefficient.

Because of the wide tolerance on the temperature coefficients quoted by manufacturers of capacitors the resulting second circuit may still not have a zero temperature coefficient even though it will normally be better than the first. Measurement of the temperature coefficient of frequency of the second circuit however enables an educated guess to be made at a third configuration of capacitors and thus will usually give the

**Table 1. Temperature coefficients of various capacitors**

Capacitor	Temperature coefficient (p.p.m./deg C)
Suflex polystyrene and RS (Radiospares) polystyrene	-150 ± 60
RS silvered mica	
values < 50pF	+75 (average)
values ≥ 50pF	+35 (average)
Lemco silvered mica	+30 ± 30
Ceramic capacitors	
P100	+100 (nominal)
NPO	0 (nominal)
N330	-330 (nominal)
N750	-750 (nominal)
Oxley Tempatrimmer	+2000 to -2000
Oxley Thermotrimmer	+1000 to -1000

result desired. The above remarks assume that only two different types of fixed capacitor are used, i.e. one having a negative coefficient and one positive.

Perhaps the neatest way of compensating for temperature effects is to use a capacitor with a variable temperature coefficient, such as the Oxley Tempatrimmer or Thermotrimmer. These are not cheap, however, and also they take up more space than equivalent fixed capacitors. The present approach is to make up a fixed capacitor with the desired temperature coefficient using a series or parallel combination of capacitors with different coefficients. Table 1 lists the quoted temperature coefficients of several types of capacitor. Since silvered mica and polystyrene capacitors have coefficients of opposite sign they are ideal for use in the way to be described.

### Definitions

If a capacitor of value  $C$  increases in value to  $C + \Delta C$  (where  $\Delta$  means 'a fraction of') for a temperature change (in degrees Celsius) from  $T$  to  $T + \Delta T$ , its temperature coefficient  $\alpha_c$  is defined as

$$\alpha_c = \frac{1}{C} \cdot \frac{\Delta C}{\Delta T}$$

and represents the change in capacitance per unit capacitance per degree Celsius. The coefficient is generally a very small fraction and it is customary to multiply it by  $10^6$  and quote it as so many parts per million per degree Celsius. Thus for a polystyrene capacitor with a coefficient of  $-150$  p.p.m./deg C the coefficient  $\alpha_c$  is actually  $-0.000150$  per deg C (or  $-0.015\%$  per deg C)

Similarly we can define a temperature coefficient of inductance ( $L$ ) and of frequency ( $f$ ). Thus

$$\alpha_L = \frac{1}{L} \cdot \frac{\Delta L}{\Delta T}$$

and

$$\alpha_f = \frac{1}{f} \cdot \frac{\Delta f}{\Delta T}$$

Because the inductance of a coil increases with its size, which in turn increases with temperature,  $\alpha_L$  is usually positive. A reduced temperature coefficient of inductance can be obtained by winding coils on ceramic formers under tension and with both wires and former at an elevated tem-

perature. On cooling to room temperature with the wire-ends anchored the wire is stretched onto the ceramic and its expansion coefficient is then that of ceramic, not copper.

In a practical oscillator circuit there are a number of ways in which temperature can affect the frequency but in a well-designed oscillator in which the active element is effectively tapped down the tank circuit (e.g., high- $C$  Colpitts, Gouriet-Clapp, Seiler, Vackar, Franklin) the effects of the maintaining circuit are slight and can be treated as part of the temperature coefficient of the coil. The latter is not open to experimental alteration so that one must alter the temperature coefficient of the total tank circuit capacitance to compensate for that of the inductance and for the other smaller effects.

It is necessary to know therefore how the temperature coefficient of frequency is related to those of inductance and capacitance and how the temperature coefficient of total capacitance of a series or parallel combination of two or more capacitors depends on their individual coefficients. The calculation is carried out in the appendix and we merely quote here the following three results.

*Coefficient of frequency of a tuned circuit*

$$\alpha_f = -\frac{1}{2}(\alpha_c + \alpha_L) \quad (1)$$

*Two capacitors in parallel*

$$\alpha_c = \left( \frac{C_1}{C_1 + C_2} \right) \alpha_{c1} + \left( \frac{C_2}{C_1 + C_2} \right) \alpha_{c2} \quad (2a)$$

$$\text{or} \quad \alpha_c = \frac{C_1}{C} (\alpha_{c1} - \alpha_{c2}) + \alpha_{c2} \quad (2b)$$

*Two capacitors in series*

$$\alpha_c = \left( \frac{C_2}{C_1 + C_2} \right) \alpha_{c1} + \left( \frac{C_1}{C_1 + C_2} \right) \alpha_{c2} \quad (3a)$$

$$\text{or} \quad \alpha_c = \frac{C}{C_1} (\alpha_{c1} - \alpha_{c2}) + \alpha_{c2} \quad (3b)$$

In these expressions  $C$  represents the total capacitance of a combination of two capacitors,  $C_1$  and  $C_2$ , which have temperature coefficients of  $\alpha_{c1}$  and  $\alpha_{c2}$  respectively. Coefficient  $\alpha_c$  refers to the total capacitance. It is easily seen that, as expected, when  $\alpha_{c1}$

and  $\alpha_{C_2}$  are identical any combination of  $C_1$  and  $C_2$  must have the same temperature coefficient as each individual capacitor.

**Experimental procedure**

A procedure for temperature compensating an oscillator is as follows.

- Measure the frequency of oscillation at two temperatures spaced by about 10 deg C,  $f_1$  at  $T_1$  and  $f_2$  at  $T_2$ . Then the temperature coefficient in p.p.m./deg C is

$$\beta_f' = \frac{1}{f_1} \left( \frac{f_2 - f_1}{T_2 - T_1} \right) \times 10^6$$

(The symbol  $\beta$  has been used to distinguish between coefficients expressed as p.p.m./deg C and just deg C<sup>-1</sup>.)

- If  $\beta_{C'}$  represents the temperature coefficient of capacitance of the circuit for which the temperature coefficient of frequency is  $\beta_f'$ , and  $\beta_{C''}$  and  $\beta_f''$  represent similar parameters for a modified circuit, the use of equation 1 gives

$$\beta_{C''} = \beta_{C'} + 2(\beta_f' - \beta_f''). \quad (4)$$

But the required value for  $\beta_f''$  is zero so that

$$\beta_{C''} = \beta_{C'} + 2\beta_f'. \quad (5)$$

- Equation 5 gives the optimum value for  $\beta_{C'}$  in terms of its initial value and the measured coefficient of frequency of the initial circuit. Using equations 2 and 3 and knowing the oscillator circuit it is a straightforward matter to calculate  $\beta_{C'}$ . One must then decide which capacitors to alter to change the total coefficient of capacitance from  $\beta_{C'}$  to its new value  $\beta_{C''}$ . Again, using equations 2 and 3 this is straightforward.
- The temperature coefficient of frequency of the new circuit is now measured and may well be adequate for the purpose. Because of the large tolerance on quoted temperature coefficients, however, this may not be the case but using the results obtained for the second circuit a third configuration of capacitors can be estimated which should further improve the temperature coefficient of frequency.
- Finally if still greater stability is desired, the three coefficients so far measured provide enough information to evaluate the actual temperature coefficients of the two kinds of capacitor used and of the inductor. With this information a further calculation of suitable capacitor values can be carried out and this should give adequate stability. In the author's experience this final stage has not been necessary.

**Example**

As an illustration of this procedure the calculation will be carried through using data obtained during construction of a 15-MHz v.f.o. used in a mixing-type v.f.o. for 70MHz.\* The Gouriet-Clapp oscillator circuit is shown in the figure. Initially capacitors  $C_2$  and  $C_3$  were miniature polystyrene types and  $C_1$  silvered mica. The total capacitance in the oscillator tank circuit can be regarded as a 150pF silvered mica capacitor in series with a 500pF polystyrene capacitor, the nominal temperature

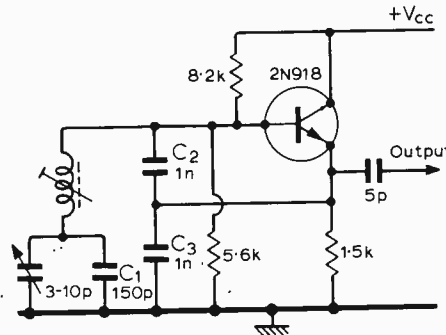

In this Gouriet-Clapp oscillator overall temperature coefficient was reduced to +3 p.p.m./deg C by using the simple equations in this article and making  $C_1$  a parallel combination of a silvered mica capacitor and a polystyrene capacitor.

coefficients being +30 and -150 p.p.m./deg C respectively (Table 1). Because of their relatively small values the tuning capacitance and the inter-electrode capacitances of the transistor can be neglected. Their temperature variations will be treated as part of those of the inductor. Steps in the stabilization process were as follows.

- When the temperature of the diecast aluminium box containing the oscillator was changed from 25 to 35°C the frequency of oscillation dropped by 1120Hz at a nominal frequency of 15.5MHz. The temperature coefficient was thus  $-1120/(15.5 \times 10) = -7.2$  p.p.m./deg C.
- The temperature coefficient of capacitance had therefore to be reduced by 14 p.p.m./deg C.
- Using equation 3a and the data in Table 1, the initial temperature coefficient of capacitance is

$$\beta_C = \left( \frac{150}{500 + 150} \right) (-150) + \left( \frac{500}{500 + 150} \right) (+30)$$

i.e.,  $\beta_C = -11.5$  p.p.m./deg C.

Therefore the required coefficient of capacitance is -25.5 p.p.m./deg C.

A convenient way to obtain this value is to keep  $C_2$  and  $C_3$  unchanged and to partially replace  $C_1$  by a polystyrene capacitor. Let the new coefficient of  $C_1$  be  $\alpha_x$ , then using equation 3a  $\alpha_x$  will be given by the following equation

$$-25.5 = \left( \frac{150}{500 + 150} \right) (-150) + \left( \frac{500}{500 + 150} \right) \alpha_x$$

from which  $\alpha_x$  is found to be 11.8 p.p.m./deg C. If  $C_1$  is made up of a parallel combination of a silvered-mica capacitor  $C_4$  and a polystyrene capacitor  $C_5$ , equation 2b can be used to find the values of  $C_4$  or  $C_5$ . Thus

$$11.8 = \frac{C_4}{150} [30 - (-150)] + (-150),$$

from which  $C_4 = 135$ pF and therefore  $C_5 = 15$ pF.

- The temperature coefficient of the circuit with these values was found to be +3 p.p.m./deg C. As this represents a drift of only 450Hz per 10 deg C change in temperature

no further changes were necessary.

As a point of interest, it is easy to estimate what the temperature drift of this oscillator would have been if all capacitors had been of one type. Thus from the third step it is clear that as the coefficient of capacitance necessary to give zero coefficient of frequency is -25 p.p.m./deg C the temperature coefficient of the rest of the components must be +25 p.p.m./deg C. Now if the capacitors were all silvered mica types, equation 1 gives

$$\beta_f = -\frac{1}{2}(30 + 25) = -27 \text{ p.p.m./deg C.}$$

This is nine times worse than the final circuit. Similarly if all the capacitors were polystyrene  $\beta_f$  would have been  $-\frac{1}{2}(-150 + 25)$ , i.e. +62 p.p.m./deg C or 20 times worse.

**Appendix**

If the frequency of oscillation of an oscillator is a function of  $L$  and  $C$  only, one may write perfectly generally the partial differential expression

$$df = \left( \frac{\partial f}{\partial L} \right)_C dL + \left( \frac{\partial f}{\partial C} \right)_L dC,$$

from which, as both  $L$  and  $C$  are functions of  $T$ , we obtain

$$\frac{df}{dT} = \left( \frac{\partial f}{\partial L} \right)_C \frac{dL}{dT} + \left( \frac{\partial f}{\partial C} \right)_L \frac{dC}{dT}. \quad (A1)$$

But the oscillator frequency is  $1/2\pi(LC)^{\frac{1}{2}}$ , so that we obtain for the partial differentials

$$\left( \frac{\partial f}{\partial L} \right)_C = -\frac{f}{2L} \quad \text{and} \quad \left( \frac{\partial f}{\partial C} \right)_L = -\frac{f}{2C}.$$

Substitution of these back into equation A1 gives

$$\frac{1}{f} \cdot \frac{df}{dT} = -\frac{1}{2} \left( \frac{1}{C} \cdot \frac{dC}{dT} + \frac{1}{L} \cdot \frac{dL}{dT} \right)$$

or  $\alpha_f = -\frac{1}{2}(\alpha_C + \alpha_L)$ .

A similar treatment can be applied to the case of two capacitors in series or in parallel. If the two capacitors are  $C_1$  and  $C_2$  with temperature coefficients  $\alpha_{C_1}$  and  $\alpha_{C_2}$ , the total capacitance ( $C$ ) is a function only of  $C_1$  and  $C_2$  thus we obtain

$$\frac{dC}{dT} = \left( \frac{\partial C}{\partial C_1} \right)_{C_2} \frac{dC_1}{dT} + \left( \frac{\partial C}{\partial C_2} \right)_{C_1} \frac{dC_2}{dT}. \quad (A2)$$

If the capacitors are in series,  $C$  is

$$C = \frac{C_1 \cdot C_2}{C_1 + C_2}$$

and the partial differentials are

$$\left( \frac{\partial C}{\partial C_1} \right)_{C_2} = \left( \frac{C_2}{C_1 + C_2} \right)^2 \text{ etc,}$$

from which we obtain

$$\alpha_C = \left( \frac{C_2}{C_1 + C_2} \right) \alpha_{C_1} + \left( \frac{C_1}{C_1 + C_2} \right) \alpha_{C_2}.$$

If the capacitors are in parallel we have  $C = C_1 + C_2$  and the partial differentials in equation (A2) are unity. The result then follows that

$$\alpha_C = \left( \frac{C_1}{C_1 + C_2} \right) \alpha_{C_1} + \left( \frac{C_2}{C_1 + C_2} \right) \alpha_{C_2}.$$

\*Tong, D. A. 'Mixer-v.f.o. for 70MHz, Radio Communication, in press.

# About People

An honorary doctorate of the University of Surrey has been conferred on **Edward Fennessy, C.B.E., B.Sc., F.I.E.E.**, managing director of Post Office Telecommunications. Dr Fennessy was a group captain on the staff of 60 Group R.A.F., and from 1942 to the end of the war led the teams that built the complexes of Gee, Oboe and other radar stations. After the war, he headed the Decca Navigator Company until 1949 when he formed the Decca Radar Company. In 1965 he became managing director of the Electronics Group of The Plessey Company and since 1969 has been a member of the board of the Post Office.

**A. A. Dyson, O.B.E.**, is the new president of the Institution of Electronic and Radio Engineers. Mr Dyson, who joined Erie Resistor Ltd in 1932, is now chairman and managing director of the United Kingdom group of this American company. In addition to Erie Electronics the group includes A. H. Hunt (Capacitors), F. C. Robinson and Partners, and Erie Controls. Mr Dyson is also a director of the parent company Erie Technological Products Inc., of Erie, Pa.

**Sir John Clark**, chairman and chief executive of The Plessey Company Limited, has become president of the Telecommunication Engineering and Manufacturing Association (TEMA). This follows the retirement of **F. C. Wright, C.B.E.**, deputy chairman of Standard Telephones and Cables, who had been president since May 1968. TEMA has also announced the appointment of three new vice-presidents: **T. P. Callaghan**, assistant managing director of Standard Telephones and Cables, **C. A. R. Pearce**, managing director of Pye TMC, and **Dr B. F. Willetts**, managing director of Plessey Telecommunications.

**Sydney R. Pitkin, B.Sc., M.I.E.E.**, has joined Redifon Telecommunications Ltd as chief engineer, Mobile Communications. Born in Colombo in 1929, Mr Pitkin joined

the radio division of Standard Telephones and Cables Ltd in 1945 as an apprentice. From 1951 to 1954 he served as a technical officer in the R.A.F., following which he studied for his degree at London University. He returned to S.T.C.'s radio division, and since 1967 has been chief engineer of ITT Mobile Communications Ltd.

**Professor Dennis Gabor, C.B.E., F.R.S.**, is recipient of the 1971 Nobel prize for physics (about £36,000) for his pioneering work in holography. Hungarian born Dr. Gabor, who came to the U.K. in 1934, joined the staff of Imperial College, London, in 1949 and in 1958 was appointed professor of applied electron physics.

The Scottish group of Ferranti Ltd has announced the appointment of **A. C. Bastable, B.Sc., M.I.E.E.**, as manager of the Professional Components Department of the company based at Dundee and Edinburgh. He takes over from **A. L. Chilcot, M.B.E.**, who will shortly be retiring. Mr Bastable (47) joined the Ferranti Technical Sales Department at Edinburgh in 1950 and after becoming sales manager of the Valve Department in 1954, moved to Dundee in 1958 to run the Ferranti activity there. The Professional Components Department, was until recently known as the Valve & Transformer Department.

**John N. Borwick, B.Sc.**, has joined Sussex University's Department of Music as senior lecturer in recording techniques. Mr Borwick studied physics, mathematics and applied mathematics at Edinburgh University from 1941 to 1943. He then spent four years in the R.A.F. as a Signals Officer and joined the B.B.C. in 1947. During his eleven years with the Corporation he spent two years as lecturer in studio operations, musical acoustics, microphone techniques, etc., at the B.B.C. Engineering School. Since leaving the B.B.C. in order to divide his time between writing, recording and broadcasting he has been technical editor of *The Gramophone*. At the University

Mr Borwick will be particularly concerned with the running and development of the recording technique aspects of the 'Tonmeister' option, one of the two options in the Surrey B.Mus. course. A Tonmeister is responsible for the musical and acoustical success of an original transmission (e.g. a radio or television studio broadcast or an outside broadcast from a concert hall, opera house or theatre) or of a recording.

KEF Electronics Ltd has announced the appointment of two new directors; **C. J. Goodman** becomes director of production and **L. R. Fincham, B.Sc. (Eng.)**, director of engineering. Mr Goodman has been with the company since 1966 having formerly been employed by Elliott Brothers Ltd in their servo-components division at Lewisham. Mr Fincham joined KEF in 1968 as chief engineer. A graduate of Bristol University he commenced his practical work in the loudspeaker field with Goodmans and was with Rola Celestion immediately prior to joining KEF.

**Peter Rainger, B.Sc., F.I.E.E.**, has become head of the B.B.C. Research Department in succession to **Dr R. D. A. Maurice**, who, as already announced, is now chief assistant to the B.B.C.'s director of engineering. Since early in 1969 Mr Rainger had been head of the Designs Department, in which he was at one time head of the television recording section. He joined the B.B.C. in 1951, after graduating at London University, and led the teams which developed the first all-electronic 525/625-line television standards converter and the first electronic 50/60 field converter. The new head of the Designs Department is **Eric R. Rout, M.I.E.E.**, who since 1967 has been head of the electronics group in the Research Department. He has been particularly associated with work on television recording, standards conversion, and the application of digital techniques to the processing of signals for television and sound broadcast-

ing. He joined the B.B.C. in 1950.

**Robin E. Davies**, of the B.B.C. Research Department receives the Vladimir K. Zworykin award of the I.E.E.E., presented for an outstanding technical contribution in the field of electronic television. "For his development of the field-store standards converter." Mr Davies, who is 36, spent two years with Decca Radar before joining the B.B.C. Research Department as a mathematician in 1958. From 1963 to 1970 he worked on television standards conversion on which he contributed an article in our January 1969 issue. Lately he has been engaged on transmission and propagation problems in radio and television.

**Clive Barwell**, a director of Mullard Ltd, is to retire at the end of December after nearly 40 years' service with the company. Mr Barwell joined the Sales Department of Mullard in 1932. During the war he was involved for a time, as production manager, in the manufacture of radio receiving valves at the Blackburn plant. After the war he handled publicity for valves and, subsequently, all Mullard products. In 1963 he was appointed head of the newly-formed Central Marketing Services Division, with overall responsibility for advertising, public relations, economic and market research and the Mullard Educational Service. Five years later he was made head of the then Industrial Electronics Division, being appointed a director of Mullard Ltd in 1970.

**Stanley Kelly**, co-founder and director of Kellar Electronics Ltd., "resigned all his offices with that company as of 30th October". Mr Kelly, who contributed the survey of stereo pickups in our December 1969 issue, has moved from Enfield, Middlesex, and is continuing his consulting service from his new address: Northdown Lodge, 145 Northdown Park Rd., Cliftonville, Thanet.



Three of these members of the teams from the B.B.C.'s Research and Design Departments responsible for developing the field-store standards converter are mentioned above. Left-to-right (front row) George Hunt, Stanley Edwardson, Robin Davies and Peter Rainger, (back row) Eric Rout, David Kitson and Robert Harvey

# 1972 Conferences & Exhibitions

Further details are obtainable from the addresses in parentheses

## LONDON

- Jan. 31-Feb. 4 Royal Horticultural Hall  
**Computer Graphics and Computer Aided Design Exhibition**  
 (U.S. Trade Center, 57 St. James's St, S.W.1)
- Mar. 14-16 Bloomsbury Centre Hotel  
**Sound '72**  
 (Association of Public Address Engineers, 394 Northolt Rd, South Harrow, Middx. HA2 8EY)
- Mar. 22-26 Skyways Hotel  
**SONEX Audio Exhibition**  
 (Federation of British Audio, 31 Soho Sq, London W1V 5DG)
- Mar. 22-29 Earls Court  
**Electrex '72**  
 (Electrical Engineers (ASEE) Exhibition Ltd, Wix Hill House, West Horsley, Surrey)
- Mar. 27-29 Grosvenor House  
**Coilwinding Convention and Exhibition**  
 (Electromation Exhibitions, 344a Holdenhurst Rd, Bournemouth, Hants.)
- Apr. 17-21 The Criterion  
**SEMINEX—Semiconductors Exhibition and Seminar**  
 (Evan Steadman & Partners, 1 St. Mark's Court, Barton Rd, Cambridge CB3 9LE)
- May 8-12 Olympia  
**Instruments, Electronics and Automation Exhibition**  
 (Industrial Exhibitions, 9 Argyll St, London W1V 2HA)
- July 25-27 Savoy Place  
**Advances in Marine Navigational Aids**  
 (I.E.E., Savoy Pl., London WC2R OBL)
- Sept. 4-8 Grosvenor House  
**International Broadcasting Convention**  
 (I.B.C., c/o I.E.E., Savoy Pl., London WC2R OBL)
- Oct. 23-28 Olympia  
**Audio Fair**  
 (Iliffe Promotions Ltd, Dorset House, Stamford St, London S.E.1)

## BRIGHTON

- Feb. 29-Mar. 2 Metropole Convention Centre  
**Electro-optics International**  
 (Sira Institute, South Hill, Chislehurst, Kent)
- Mar. 20-24 Exhibition Halls  
**Oceanology International**  
 (Oceanology International, 6 London St, London W.2)
- June 13-15 Metropole Convention Centre  
**Communication '72 Conference & Exhibition**  
 (E.T.V. Cybernetics Ltd, 21 Victoria Rd, Surbiton, Surrey)
- Sept. 18-20 The University  
**Point Defects and their Aggregates in Metals**  
 (Inst. Physics, 47 Belgrave Sq., London SW1X 8QX)
- Sept. 26-28 Metropole Convention Centre  
**Power Sources Symposium**  
 (Int. Power Sources Symposium, P.O. Box 136, 26 Wellesley Rd, Croydon, CR9 2EG, Surrey)

## CRANFIELD

- Mar. 20-23 Cranfield Institute of Technology  
**Aerospace Instrumentation Symposium**  
 (N.O. Matthews, Dept. of Flight, Cranfield Institute of Technology, Cranfield, Bedford)

## EDINBURGH

- Mar. 27-29 The University  
**Ferroelectrics and their Applications**  
 (Inst. Physics, 47 Belgrave Sq., London SW1X 8QX)

## FARNBOROUGH

- Sept. 4-10 R.A.E.  
**Electronics in Aviation**  
 (S.B.A.C., 29 King St, St James', London S.W.1)

## GUILDFORD

- Apr. 11-13 University of Surrey  
**Industrial Measurement and Control by Radiation Techniques**  
 (I.E.E. Conference Dept., Savoy Pl., London WC2R OBL)
- July 10-13 University of Surrey  
**Vacuum Instruments and Methods in Surface Studies**  
 (British Vacuum Council, 47 Belgrave Sq., London SW1X 8QX)

## KEELE

- Sept. 20-22 The University  
**Automatic Testing Systems**  
 (I.E.E. Conference Dept., Savoy Pl., London WC2R OBL)

## LANCASTER

- Sept. 12-15 The University  
**ESSDERC — European Solid State Device Research Conference**  
 (Inst. Physics, 47 Belgrave Sq., London SW1X 8QX)

## LOUGHBOROUGH

- Apr. 11-13 University of Technology  
**Digital Processing of Signals in Communications**  
 (I.E.R.E., 8-9 Bedford Sq., London WC1B 3RG)

## MANCHESTER

- Jan. 4-6 U.M.I.S.T.  
**Solid State Physics**  
 (Inst. Physics, 47 Belgrave Sq., London SW1X 8QX)
- Sept. 6-12 U.M.I.S.T.  
**Electron Microscopy**  
 (Inst. Physics, 47 Belgrave Sq., London SW1X 8QX)

## READING

- July 19-21 The University  
**Defects in Semiconductors**  
 (Inst. Physics, 47 Belgrave Sq., London SW1X 8QX)

## SHEFFIELD

- Apr. 18-20 The University  
**On-Line Computer Control Systems**  
 (I.E.E. Conference Dept., Savoy Pl., London WC2R OBL)

## SOUTHAMPTON

- Jan. 10-12 The University  
**Surface Physics of Semiconductors**  
 (Inst. Physics, 47 Belgrave Sq., London SW1X 8QX)

- Apr. 18 & 19 The University  
**Electrostatics Seminar**  
 (Inst. Physics, 47 Belgrave Sq., London SW1X 8QX)
- Apr. 25-28 The University  
**Computer Aided Design**  
 (I.E.E. Conference Dept., Savoy Pl., London WC2R OBL)
- Sept. 25-26 The University  
**Electro-Optic Systems in Flow Measurement**  
 (Inst. Physics, 47 Belgrave Sq., London SW1X 8QX)

## SWANSEA

- July 4-6 University College  
**Radio Receivers and Associated Equipment**  
 (I.E.R.E., 9 Bedford Sq., London WC1B 3RG)

## TEDDINGTON

- Apr. 12-14 N.P.L.  
**Machine Perception of Patterns and Pictures**  
 (Inst. Physics, 47 Belgrave Sq., London SW1X 8QX)

## UXBRIDGE

- Sept. 4-7 Brunel University  
**Online '72 — Computing Conference**  
 (Brunel University, Uxbridge, Middx.)

## YORK

- Apr. 10-13 The University  
**Thin Films Interfacial and Surface Phenomena**  
 (Inst. Physics, 47 Belgrave Sq., London SW1X 8QX)

## OVERSEAS (JAN.-APR.)

- Jan. 31-Feb. 4 Asilomar, Cal.  
**Information Theory**  
 (I.E.E.E., 345 East 47th St, New York, N.Y. 10017)
- Feb. 11-14 Antwerp  
**AUDIANT '72 — Hi-Fi Exhibition**  
 (J. Elsmoortel, Hi-Fi Studio, Rombaut Kelder-mansstraat 8, B 2520 Edegem, Belgium)
- Feb. 14 & 15 Philadelphia  
**Psychology of Technical Communications**  
 (I.E.E.E., 345 East 47th St, New York, N.Y. 10017)
- Feb. 14-18 Tampa  
**Applied Communications Systems Engineering**  
 (Dr. G. W. Zobrist, Department of Electrical and Electronic Systems, University of South Florida, Tampa, Florida 33620)
- Feb. 15 & 16 Dallas  
**Electronics 1985**  
 (Electronic Industries Association, 2001 Eye St., N.W., Washington, D.C. 20006)
- Feb. 16-18 Philadelphia  
**Solid-state Circuits**  
 (I.E.E.E., 345 East 47th St, New York, N.Y. 10017)
- Mar. 9-14 Paris  
**Festival du Son**  
 (Société pour la Diffusion des Sciences et des Arts, 14 rue de Presles, 75 — Paris XV<sup>e</sup>)
- Mar. 14-18 Hanover  
**DIDACTA — Educational Materials**  
 (Deutsche Messe- und Ausstellungs-AG, D-3000 Hannover-Messegeleände)
- Mar. 20-23 New York  
**IEEE Intercon**  
 (I.E.E.E., 345 East 47th St, New York, N.Y. 10017)
- Apr. 4-6 New York  
**Computer-communications Networks and Tele-traffic**  
 (Polytechnic Institute of Brooklyn, 333 Jay Street, Brooklyn, New York 11201)
- Apr. 6-11 Paris  
**Components Show**  
 (Société pour la Diffusion des Sciences et des Arts, 14, rue de Presles, 75 — Paris XV<sup>e</sup>)
- Apr. 10-12 Santa Barbara  
**Acoustical Holography**  
 (I.E.E.E., 345 East 47th St., New York, N.Y. 10017)
- Apr. 10-13 Kyoto  
**Intermag: Magnetics Conference**  
 (Intermag 72 Secretariat, KDD Research & Development Lab., 1-23 Nakameguro 2-chome, Meguro-ku, Tokyo)

# World of Amateur Radio

## The 38th president

On January 7th, ('Tim') Hughes, T.D., D.L.C., G3GVV, is to be installed as the 38th president of the Radio Society of Great Britain; early presidents names read like an honour roll of electronics (A. A. Campbell-Swinton, Erskine Murray, Admiral Sir Henry Jackson, W. H. Eccles and Sir Oliver Lodge). For many years the R.S.G.B. has represented British amateurs in questions of national and international licences and frequencies. But, like many similar organizations, the society has been facing the problems of inflation; last year the society overspent its income by £7200 and its reserves are now only half what they were two years ago. Despite increases in subscriptions, 1972 is not likely to be an easy year.

Much depends on the quality and outlook of its leadership; so, on behalf of 'W.o.A.R.', we recently put a series of questions to Tim Hughes, whose interest in amateur radio began in the 1930s, obtaining his licence in 1950. His entry into the hobby took the course of being encouraged by a neighbour who was an amateur; he was attracted first by interest in the problems of constructing equipment, secondly by the pleasure of listening. He admits that possibly, over the years, his priorities have been reversed; but he still always has some device in embryo — test equipment, audio equipment, or v.h.f. equipment. He also remains an extremely active amateur, on the air almost every day, using h.f. single-sideband from his home in Tonbridge, or operating v.h.f. portable from many parts of the country. But what are his views on matters of topical concern?

He questions the commonly held view that British amateurs are drifting in large numbers from h.f. to v.h.f., though he believes that more genuine experimental work is carried out on v.h.f./u.h.f. than on h.f. He also feels that, with the wider frequency allocation on the higher frequency bands, there is greater need for amateurs to occupy fully the v.h.f./u.h.f. bands, which give beginners a chance of achieving good results with simple, low-power, inexpensive home-built equipment.

On the ever-burning topic of c.w. or 'phone operation, he admits to admiring

good c.w. operation but feels this may (alas) be a dying craft — pointing in confirmation to what is happening in professional communications.

As contributory factors to the greater use of commercially built equipment he notes the perennial shortage of time, the ever-growing complexity of equipment, and the difficulty of obtaining some types of components. Yet he does not feel that the spirit of amateur radio is being affected by the 'black box' concept: "We continue to discuss and read technical matters, as before — perhaps we operate more. Because we drill less aluminium, wind fewer coils, solder fewer joints, we are no less interested nor less enthusiastic". He rejects the use of such phrases as the 'traditional concepts' of amateur radio, noting that electronics continues to develop rapidly, so that amateurs should be forward-looking, not only accepting but welcoming change.

Tim Hughes would oppose any form of incentive licensing on the grounds that, since there are only limited frequencies available to amateurs, in any such scheme some would inevitably lose frequencies. He feels it would be impertinent to suggest to British amateurs, whom he sees as great individualists, that they should concentrate on particular aspects of the hobby though he admits to a personal wish to see a general improvement in 'phone operating procedure.

He also confesses that what he would like to see during his term of office is an increase in membership; he feels that the greater the number of licensed amateurs within their national society, the more support it has when representing them at national or international level. As a member of the teaching profession he adds another wish: that every member will assist some young person to become a licensed amateur.

## More c.w. on v.h.f.?

Whether or not c.w. is a dying craft, efforts are currently being made to increase telegraphy operation on the v.h.f. bands, particularly 144MHz where the advantages of this mode of operation for relatively long-distance contacts, even under unfavourable propagation conditions, are becoming more and more

evident from a series of regular 'skeds' between British amateurs.

Peter Jones, G2JT, of Oldham, Lancashire, for example, has been making, without fail since May, 1971, daily 'good solid contacts' on 144MHz with R. A. Norrington, G3IUD, at The Lizard, well over 200 miles away. Similarly, A. E. Ashby, G3HCW, near Leeds, works H. G. Hughes, G4CG, in Barnstaple, Devon, over 230 miles away, making contacts three times out of four; he also often works G3IUD at The Lizard. German v.h.f. enthusiasts are dedicating Tuesday evenings to greater use of c.w., and the German D.A.R.C. has instituted a v.h.f. telegraphy (c.w.) award. On a much lower frequency, Dutch amateurs have for some time been running a regular Sunday morning c.w. net on 3.5MHz to encourage more use of this mode.

## Amateurs down-under

The number of amateur licences in Australia is now over 6350, of which 4520 are 'full licences' and just over 1830 'limited' (v.h.f. only); this represents about 1 in 2000 of the population, compared with about 1 in a little over 3000 in the U.K. — but a lower concentration than in New Zealand. A current debate is over the possibility of introducing a 'novice' licence permitting the use of ten-watt, crystal-controlled c.w. transmissions on 3.5, 7, 21 and 28 MHz after only a five-word-per-minute Morse test. Australian amateurs have been protesting (once again) at the high custom import duties on amateur equipment (typically 45%, or 27½% U.K. and commonwealth, plus 15% sales tax). CQ-TV reports that Maitland Lane, VK5AO/T, in South Australia, is transmitting PAL colour television using a three-vidicon camera. A note from Peter Cole, VK6AI (formerly G3JFS), says that the 28MHz path to the U.K. is often open, as denoted by the reception of the GB3SX beacon, but contacts are rare since many British stations have deserted 28 MHz in these low-sunspot years. He adds that VK6AI, AJ, CF, KW and PM are all regularly on the band.

## In brief

Long-distance reception of television broadcasting has given rise to a new Union of European Testcard Hunters with some 60 members in the Low Countries hoping to encourage the exchange of news and information on an international basis (Foreign secretary is P. D. van der Kramer, Diepenbrockstraat 2, Slikkerveer 3210, Netherlands); a similar organization catering for 'FM-DX' is the Benelux DX Club (P.O. Box 2027, Den Bosch 4004, Netherlands) . . . Permission has been granted for a 50.5MHz beacon station in Cyprus — this could prove particularly useful to stations in Rhodesia and South Africa for investigating transequatorial propagation . . . 8P6DR in Barbados is active on 1803kHz at weekends . . . ZD9BM in Tristan Da Cunha is also active again. PAT HAWKER, G3VA

# January Meetings

*Tickets are required for some meetings: readers are advised, therefore, to communicate with the society concerned*

## LONDON

5th. IERE — "A simulator for testing collision avoidance systems" by W. H. Shuffleton at 18.00 at Engineering Lecture Theatre, University College, Torrington Pl., W.C.1.

10th. IEE — Colloquium on "Ion implantation techniques" at 14.00 at Savoy Pl., W.C.2.

11th. AES — "Distortion in loudspeakers caused by low frequency signals" by H. D. Harwood at 19.15 at the Mechanical Engineering Dept., Imperial College, Exhibition Rd., S.W.7.

12th. IEE — "New memory technologies" by D. H. Roberts at 17.30 at Savoy Pl., W.C.2.

12th. IERE — "Funding of innovation" by Dr. B. C. Lindley at 18.00 at Engineering Lecture Theatre, University College, Torrington Pl., W.C.1.

18th. IEE — "The operation of the Eurovision system" by A. Elliot at 17.30 at Savoy Pl., W.C.2.

19th. IERE — "Optical communications" by D. Williams at 18.00 at 9 Bedford Sq., W.C.1.

20th. BCS — "Government computer policy" by I. Maddock at 18.30 at Engineering Lecture Theatre, University College, Gower St., W.C.1.

25th. IEE — Discussion on "Novel types of aerials" at 17.30 at Savoy Pl., W.C.2.

25th. IERE/IEE — Colloquium on "Computers in communications" at 14.30 at Savoy Pl., W.C.2.

26th. IEE — "New mathematics — is it relevant to modern science and engineering?" by Prof. M. Bruckheimer and N. Gower at 17.30 at Savoy Pl., W.C.2.

26th. I. Navigation — "Ship navigation — the means and the end" by F. M. Foley at 17.00 at the Royal Institution of Naval Architects, 10 Upper Belgrave St., S.W.1.

27th. IEE/I.Meas.C. — Colloquium on "Living with unreliability in computer based control systems" at 17.30 at Savoy Pl., W.C.2.

28th. IEE/IERE — Colloquium on "Biomedical telemetry" at 14.00 at Savoy Pl., W.C.2.

## ABERDEEN

18th. IEE Grads — "Modern developments in aerials for radio telescopes and satellite earth stations" by R. Baldwin at 19.30 at Robert Gordons Institution of Technology.

18th. IERE — "Training of radio and television broadcasting engineers" by H. Henderson at 19.30 at Robert Gordon's Institute of Technology, Physics Department Lecture Theatre, St. Andrews St.

## BELFAST

4th. IEE/IERE — "Decca, Loran, Omega: amphibious aids to navigation" by C. Powell at 17.45 at Ashby Institute, Stranmillis Rd.

## BIRMINGHAM

13th. IEE — "Electronic ignition timing" by J. E. Ridley at 19.30 at the Dept. of Electronic & Electrical Engineering, Birmingham University.

19th. IEETE — "Birmingham Radio Tower — planning, construction and commissioning" by J. R. Tiplle at 19.00 at Midlands Electricity Board District Offices, Summer Lane.

24th. IEE — "The telecommunications industry" by Dr. D. M. Leakey at 18.00 at M.E.B. Offices, Summer Lane.

## BOURNEMOUTH

11th. IERE — "The digital magnetic recording and recovery of flight data" by F. Goatcher at 19.00 at the Technical College.

## BRISTOL

11th. IEE Grads — "Medical electronics" by M. A. Bullen at 19.30 at Bristol Royal Inf., Horfield Rd.

26th. IEE/IERE/R.Ac.S. — "Space communications" by Dr. T. F. Howell at 18.00 at Queens Bldg., The University.

## CAMBRIDGE

27th. IERE — "Videophone" by Dr. D. E. Pearson at 18.30 at The University Engineering Laboratories, Trumpington St.

## CARDIFF

17th. IEE — "Ergonomics and electronic equipment" by Prof. Murrell at 18.00 at U.W.I.S.T.

## CHATHAM

27th. IERE — "Gauging techniques using radio isotopes" by T. R. Woodruff at 19.00 at The Medway College of Technology.

## CHELMSFORD

12th. IEE/IERE — "Electronics in crime detection" by A. T. Torlesse at 18.30 at King Edward VI Grammar School, Broomfield Rd.

## COVENTRY

19th. IEETE — "Electronics in crime detection" by A. T. Torlesse at 18.45 at Coventry Technical College, Butts.

## CREWE

10th. IEE — "Tomorrow's world in telecommunications" by W. J. Bray at 19.00 at MANWEB, Macon Way.

## DERBY

18th. IEE — "Some aspects of industrial telemetry" by D. W. Hoare and J. M. Ivison at 19.00 at the Technical College.

## DUBLIN

20th. IEE — "The evolution of modern carrier frequency transmission equipment" by J. Walters at 17.30 at the Physical Lab., Trinity College.

## EDINBURGH

11th. IEE — "Electronic techniques in archaeology" by M. J. Aitken at 18.00 at the S.S.E.B., George St.

20th. IEETE — "Area traffic control experiment in Glasgow" by John A. Ferguson at 18.00 at Heriot-Watt University.

19th. IERE — "Training of radio and television broadcasting engineers" by H. Henderson at 19.00 at Napier College of Science and Technology, Colinton Rd.

20th. BCS — "Traffic control" by G. R. Wilson at 18.00 at Mountbatten Building, Heriot-Watt University.

## GLASGOW

10th. IEE — "Electronic techniques in

archaeology" by M. J. Aitken at 18.00 at the Institution of Engineers & Shipbuilders, Rankine House, Bath St.

19th. IEETE — "Area traffic control experiment in Glasgow" by John A. Ferguson at 18.00 at Institution of Engineers & Shipbuilders, Rankine House, Bath St.

20th. IERE — "Training of radio and television broadcasting engineers" by H. Henderson at 18.00 at The Institution of Engineers and Shipbuilders, Rankine House, Bath St.

## GLOUCESTER

19th. IERE — "There is more to colour than wavelength" by M. Brocklebank at 19.00 at the Technical College.

## GUILDFORD

26th. IERE — "New project management" by W. D. Laurence at 18.30 at University of Surrey.

## LEEDS

19th. BCS — "PERT in a d.p. environment" by B. C. Welch at 18.45 at The University.

## LLANDAFF

12th. IERE — "The Dolby noise reduction system" by S. Kelly at 18.30 at Broadcasting House.

## MALVERN

10th. IEE — "Radar studies of clear air" by C. D. Watkins at 19.30 at Promenade Restaurant.

## MANCHESTER

5th. IEE — "Manning of the u.h.f. broadcasting services" by B. Davis at 18.15 at U.M.I.S.T., Sackville St.

11th. IEE — "Electronics in cars" by L. J. Cripps at 18.15 at U.M.I.S.T., Altrincham St.

13th. IERE — "Planning and provision of country-wide data transmission networks" by W. A. Ellis at 18.15 at The Renold Building, U.M.I.S.T., Altrincham St.

## NEWCASTLE-UPON-TYNE

3rd. IEE — "Machine intelligence" by R. Popplestone at 18.30 at the Polytechnic.

12th. IERE/I.Meas.C. — "High-quality audio amplifiers" by K. C. Johnson at 18.30 at The Ellison Building, The Polytechnic.

## NEWPORT, MON.

19th. IEETE — "Technician engineers and technicians — their role and enhanced status through registration — and their future" by E. A. Bromfield at 19.30 at Newport & Monmouthshire College of Technology, Allt-yr-yn Avenue.

## OXFORD

12th. IEE — "The new data network" by F. R. E. Dell at 19.00 at the Oxford Polytechnic, Headington.

## READING

5th. IEETE — "Technician engineers and technicians — their role, their status, their future" by E. A. Bromfield at 19.30 at College of Technology, Kings Road.

20th. IERE — "Electronic aid for the disabled" by D. J. Rowley at 19.30 at the J. J. Thomson Laboratory University of Reading, Whiteknights Park.

## SALISBURY

31st. IEE — "Telecommunications — past, present and future" by J. S. Williams at 18.30 at Salisbury & S. Wilts. College, Southampton Rd.

## SHEFFIELD

25th. IEE Grads — "Recent developments in radio astronomy" by H. G. Muller at 19.30 at the University.

27th. IERE/I.Meas.C. — "Laser applications" by N. Forbes at 19.30 at Sheffield Industries Exhibition Centre, Carver St.

## SOUTHAMPTON

19th. IERE — "The Skynet II satellite programme" by W. M. Lovell at 18.30 at Lanchester Theatre, The University.

24th. IEE — "Training for research" discussion opened by Dr. J. R. Tillman at 18.30 at Southampton University.

## WEYMOUTH

20th. IEE — "Sonar or ultrasonics" at 18.30 at S. Dorset Technical College, Newstead Rd.

# New Products

## Thyristor for pulse modulation

Thyristor type BTW35 from Mullard is designed for use as a pulse modulator in radar equipment. It can switch peak powers up to 60kW at 5kHz, and has a maximum repetitive off-state voltage rating of 600V. The thyristor has a  $di/dt$  rating of 1000A/s. Other details are as follows:

maximum crest working off-state voltage	500V
maximum repetitive peak on-state current (half sinewave, $t \leq 1 \mu s$ )	100A
maximum rise time ( $I_{TM} = 40A$ , 10 to 90%)	400ns
maximum junction temperature	100°C
encapsulation	SO-35A

The use of the thyristor in direct-switching line-type modulators to drive radar magnetrons with outputs up to 2kW is described in a technical note entitled 'Pulse-modulator thyristor BTW35 as a radar magnetron driver'. Requests for the application note, reference number TP1267, should be made to the Instrumentation and Control Electronics Division, Mullard Ltd., Mullard House, Torrington Place, London WC1E 7HD. WW 301 for further details (device) WW 302 for further details (application note)

## Encapsulated charging modules

The CE-180 series of constant current battery charging modules from Crowborough Electronics, intended for wiring into equipment operating from nickel



cadmium rechargeable cells, can supply any pre-set current up to 180mA in increments of 5mA, or up to 30mA in increments of 1mA. The currents are adjusted to within 2½% of the required value. The available output voltage is set by the manufacturer according to the number of cells to be charged. The circuit provides a constant charging current, which is stabilized against normal mains and battery voltage variations. The battery is also protected against discharge during mains failures. Each module includes a double-wound mains isolating transformer, bridge rectifier, and current regulating circuit. Silicon semiconductors are used throughout, and the unit is completely encapsulated in epoxy resin. 300mm flexible leads are provided for mains and battery connections. Normal mains input is 230/240V, 50/60Hz, but a 110/115V version can be supplied. The chargers are intended for permanent connection to the battery. Outputs available: 1 to 30mA for up to 20 cells, 35 to 100mA for up to 15 cells, 105 to 180mA for up to 10 cells. Crowborough Electronics, Eridge Road, Crowborough, Sussex.

WW 304 for further details

## R. F. chokes

High-quality r.f. chokes designated SC10 and SC60 are being currently manufactured by Sigma Products. The SC10 measures 9.5 × 4.5mm with a rating of 1/3W at 70°C and is available ex-stock from 0.1 μH to 1mH. The SC60 is a magnetically screened version, the electrical characteristics of which can be designed to suit individual requirements, with inductance values up to 100mH. Sigma Products, 72 St. Andrews Road, Northampton. WW 305 for further details

## Automatic i.c. tester

I.C. tester type AT100B from Davian is capable of checking almost every type of logic module, including the 74 series m.s.i. range. It subjects the device under test to every possible combination of logic conditions over the range of voltage levels and

loadings specified by the manufacturer: Inability of the device to perform correctly in any one or more of these conditions results in a 'fail' indication.

The tester functions on the principle of logic pattern comparison between the i.c. under test and an 'ideal' logic equivalent. The pattern comparison is made at both the input and the output terminals of the device and its ideal equivalent, so that the effects of input noise margins and leakage current are taken into account.



The test programme also includes checking performance for each combination of input conditions over a range of output loadings. Price £1,365. Davian (Instruments) Ltd, 52 Cardigan Street, Luton LU1 1RR. WW 306 for further details

## Analogue simulator

The 'Samourai' range of S.F.E.N.A. miniature analogue simulators, made in France, is available in the U.K. from Moore Reed & Co. Each unit provides a system of blocks simulating elementary linear transfer functions and typical non-linearities of control loops. Input and output characteristics are adjusted by digitally scaled ten-turn potentiometers on the front panel. The functional blocks include inverting summing amplifiers, open-loop operational amplifiers, fixed and adjustable gain circuits, integrators, time constants, and a test signal generator. The power requirement is 220V a.c. (50Hz or above). Size is 472 × 310 × 165mm. Weight 6.5kg. Moore Reed & Co. Ltd., Walworth Industrial Estate, Andover, Hampshire. WW 311 for further details

## Tapered waveguide transitions

Flann Microwave have introduced a range of waveguide-to-waveguide tapers providing transitions between many waveguides

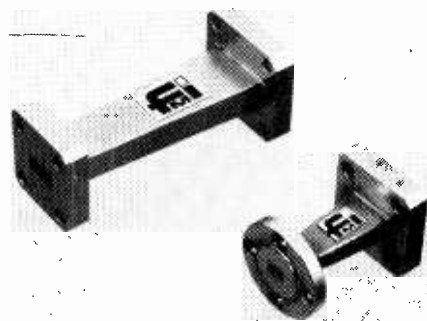

within the frequency range 1.12 to 300GHz. The length of each transition is sufficient to offer a low v.s.w.r. to the transmitted power. The tapers are supplied with flanges soldered in position. Flann Microwave Instruments Ltd., Dunmere Road, Bodmin, Cornwall.

WW 309 for further details

### Variable transformers

Two medium-power Philips variable transformers are available from Rilton Electronics. Model 14406 with a rating of 6.5/7.5A is priced at £14.20 and model 15406 with a rating of 10/12A at £18.30. Both

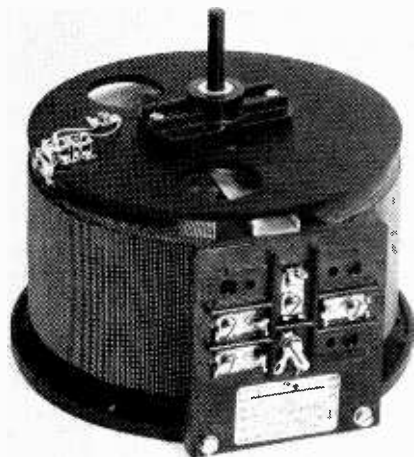

types operate on an input of 240V and an output of 0-240V, 50-400Hz. Both units have a silver alloy plated track and adjustable spindles for back-of-panel mounting. Rilton Electronics Ltd., 13 Harecombe Rise, Crowborough, Sussex.

WW 307 for further details

### Zener and avalanche diodes

A range of silicon high-power zener and avalanche diodes from Semitron offer a wide choice of voltages at a 75W rating. The diodes, type Z6B, are available in preferred voltages from 3.6 to 200V. They provide power regulation, clipping and surge protection, providing 5kW dissipation for 50 s. For clipping applications diodes can be tested to meet specific surge ratings. Maximum junction temperature is 200°C and storage temperature -55° to +180°C. The package is SO13 (JEDEC DO5). Semitron Ltd., Cricklade, Wilts.

WW 308 for further details

### Modem simulator

A range of modem simulators, manufactured by Lion Systems Developments, interface data transmission equipment. The desk model illustrated has internal preset frequencies of 1200/2400/4800/9600 bauds which are crystal controlled for synchronous operation. Further models

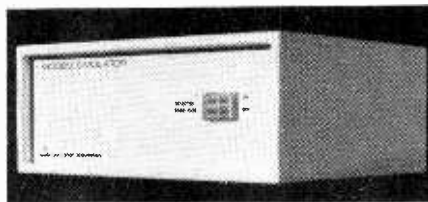

include facilities for asynchronous operation without internal oscillator, variable frequency from 1000 to 10,000 bauds (internal or external control), rack mounting, and monitoring and measurement with controls for test purposes. Lion Systems Developments (Gerrards Cross) Ltd, 45-47 Station Road, Gerrards Cross, Bucks.

WW312 for further details

### Relay simulator

Feedback Instruments have designed a relay simulator and non-linear unit (type 150G) as an addition to the Feedback Servo MS150 teaching aid. The unit provides electronically generated non-linear characteristics with control over all parameters. In conjunction with the servo-system, or by itself, it provides means of studying on-off type control systems with two-step and three-step control characteristics, the effects of controlled backlash and deadband or continuous servo systems, phase-plane methods of analysis of non-linear systems, and the graphical meaning

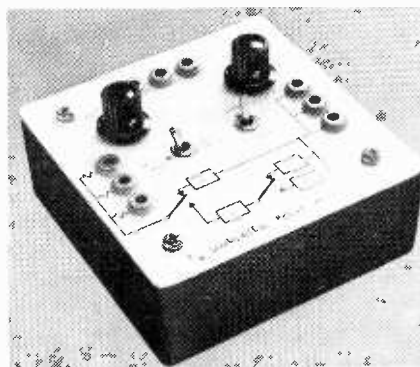

of non-linear terminology ('deadband' etc). Power requirements are  $\pm 15V$ . Price £49. Feedback Instruments Ltd, Park Road, Crowborough, Sussex.

WW313 for further details

### Miniature filters

A range of 5MHz to 100MHz lumped circuit filters is available, from Texscan, in band-pass and low-pass configurations. Made to customers' requirements they can

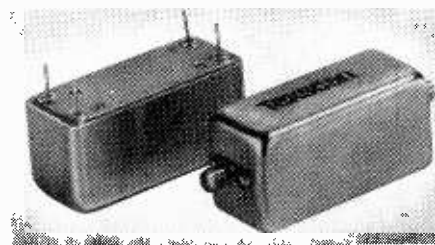

be supplied in 3 to 8 sections for 50 or 75 $\Omega$  working, and fitted with solder lugs or a choice of standard connectors. An eight section sharp cut-off filter typically measures 51 x 25 x 25mm. The filters have an average power rating of 25W. Texscan Instruments Ltd, Lord Alexander House, Hemel Hempstead, Herts.

WW314 for further details

### Single-turn sealed wire-wound potentiometer

A half-inch diameter, fully sealed, wire-wound single-turn potentiometer, in a resistance range from 10 $\Omega$  to 50k $\Omega$ , is available from Reliance Controls. Obtain-

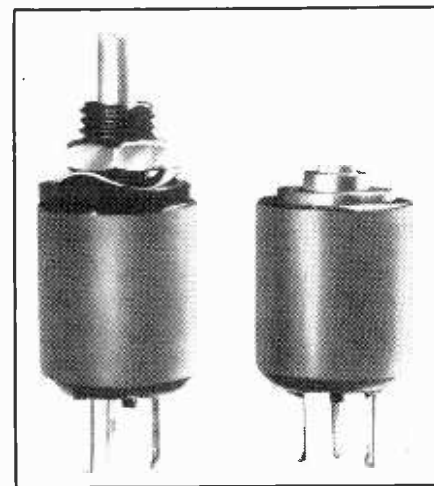

able in panel or p.c. mounting versions, designated CWO5 and CWO6 respectively, this potentiometer provides 0.6% resolution and 20 p.p.m. temperature coefficient for 500 $\Omega$  and 0.14% resolution and 20 p.p.m. t.c. for 50k $\Omega$ . Electrical rotation is 300°  $\pm 5^\circ$ ; mechanical rotation 305°  $\pm 5^\circ$ . Rating is 0.75W at 40°C, and temperature range -40° to +100°C. Reliance Controls Ltd., Drakes Way, Swindon, Wilts.

WW317 for further details

### Soldering iron with ceramic shaft

The CCN series of soldering irons from Antex has the element enclosed in an aluminium oxide shaft. The makers claim that insulation is so high that transistors can be soldered 'live' without any risk of damage. The rating of each iron is 15W. Length is 18cm and weight 28gm. Voltage ratings are 220-230 or 230-240V. Antex Ltd., Mayflower House, Plymouth, Devon.

WW 310 for further details

### Sampling a.c. voltmeter

The Dranetz series 215 voltmeter, available from Euro Electronic Instruments, analyses transients, repetitive waveforms and multiplexed signals. Accuracy is to 2% of reading +0.5% full scale in the range





100Hz to 1MHz. There are six ranges from 0.1 to 5V full scale, and probes are available to extend the range to 5000V. Sampling periods of 0.1, 1 or 10ms can be set by front panel switches, and sampling rates varied by an external a.c. gating signal from 1 sample/2.5s to 1000 samples/s or controlled by an internal generator at a constant rate of 10 samples/s. Measurement can be made for signals as short as 1 cycle, and a sample-and-hold d.c. output is provided for driving external equipment. Euro Electronic Instruments Ltd, Shirley House, 27 Camden Road, London N.W.1. **WW315 for further details**

### Dual-trace 50MHz 'scope

A 50MHz 'scope has been announced by Cossor Electronics. Model 4000 has large bandwidth at constant sensitivity, delayed timebase including gated delay facilities, a beam finder and a  $8 \times 10$ cm display.

#### Specification

vertical deflection (2 identical channels)  
bandwidth and rise time d.c. to 50MHz, 7ns  
deflection factor 5mV/cm to 10V/cm at full bandwidth  
input impedance  $1M\Omega$  in parallel with 24pF  
horizontal deflection  
calibrated timebase 0.1 $\mu$ s/cm to 2s/cm  
 $\times 10$  magnifier operates over full time base, increases fastest sweep rate to 10ns/cm  
calibrated sweep delay 1.0 $\mu$ s to 100ms decade steps  
X-Y operation 50mV/cm and 500mV/cm or channel 2 can drive horizontal at 5mV/cm



Power requirement is 100-125V or 200-250V from 48Hz to 440Hz. Consumption 120VA. Price £650. Cossor Electronics, The Pinnacles, Elizabeth Way, Harlow, Essex.

**WW318 for further details**

### Power signal sources

Two r.f. signal generators providing up to 50W are available from Airborne Instruments Laboratory — type 125 with a range of 200 to 3000MHz, and type 126 ranging from 2 to 8GHz. Increased power is available from type 125 by the addition of an external power supply unit. Both generators have internal square wave modulation at 1kHz and inputs for

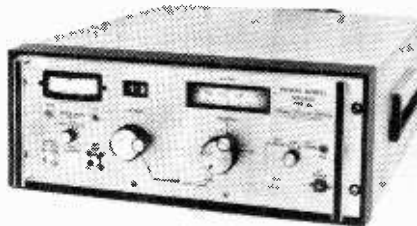

square-wave and pulse modulating waveforms. Harmonics are 40dB down on the 125 and 45dB down on the 126. AIL (a division of Cutler Hammer Inc.), Sherwood House, High Street, Crowthorne, Berks.

**WW320 for further details**

### Quartz crystal units

A range of high-stability close tolerance, AT cut 3rd overtone crystal units, covering the frequency range 20-60MHz is available from McKnight Crystal Co. They are available in U.K. crystal holder styles D, J and K. Designed for very close channel spacing v.h.f. and u.h.f. equipment, the crystals can be supplied with frequency temperature variations as low as 7.5 p.p.m. from  $-20^\circ$  to  $+70^\circ$ C. Versions for operation in crystal ovens at  $75^\circ$ C with corresponding temperature coefficients as low as 0.1 p.p.m./deg C are also available. Each version can be supplied with calibration errors to a minimum of  $\pm 10$  p.p.m. at series resonance operation. For less exacting applications crystals between

20-60MHz can also be supplied to a standard tolerance of  $\pm 0.005\%$  measured at  $25^\circ$ C and series resonance. McKnight Crystal Company, Unit 21, Shipyard Estate, Hythe, Southampton, Hants. **WW319 for further details**

### TV camera for low light conditions

Two low light-level television cameras made by Cohu Electronics are available from Litton Precision Products International Inc. The 4250/4350 series cameras provide a usable picture with only 0.03 lux (less than the light of a quarter moon) illumination on the image tube, and they can also be aimed directly at the sun without damaging the silicon diode-array vidicon. Both cameras have identical semiconductor circuitry.



The 4250 series camera is enclosed in a rugged aluminium alloy housing, and can withstand heat, cold, dust or 100% humidity. The 4350 series camera is intended for indoor use and has controls on the rear panel.

Horizontal centre resolution is 650 lines with 350 lines vertical centre. Output is composite video or modulated r.f. Scanning is random interlace with 2:1 interlace optional without camera modification. An optional automatic lens control covers a wide range of scene brightness changes. Accessories include a variety of fixed focal length lenses, fixed mounting devices and pan and tilt units. Litton Precision Products International Inc., 95 High Street, Slough, Bucks. **WW321 for further details**

### R.F. swept-frequency generator

Covering the range 20kHz to 70MHz in ten overlapping bands, the Multisweep ED3 made by Dinosaur Electronics Ltd. is a swept-frequency and marker generator for use, with a c.r.o., in frequency response testing of communications and television equipment. An unusual feature is that the basic oscillator is a multivibrator (the frequency of which is swept by a control voltage), followed by a low-pass twin section RC filter to attenuate the harmonics in the square wave and leave a near-pure sine wave. With this system the frequency stability is claimed to be better than 0.2% of centre frequency per hour, after an hour's warm-up, and the residual f.m. to be less than 0.02% pk-pk. The test frequency

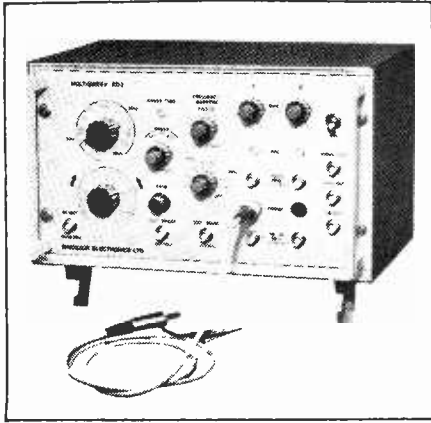

(1.4V r.m.s., 50Ω can be swept by internal or external means; the sweep width is continuously adjustable down to 0.1% of the full band; and there is an oversweep indicator.

The instrument includes twin display channels, each with gain and vertical shift controls, for receiving the response signal of the equipment under test (via an optional active probe), and a beam switch to provide a dual trace display on a single-beam c.r.o. The crystal-generated frequency-marker system allows selection of one of seven harmonic 'combs' with marker intervals ranging from 10kHz to 10MHz, and this can be switched to either or both channels. Alternatively, external marker signals may be applied. Price £398; active probe £28. Dinosaur Electronics Ltd. Agents: Lingrael Ltd., Cardigan House, Waterloo Road, Winton. Bournemouth, BH9 1AU. WW329 for further details

### Logic tester

The 80A logic tester from Ryley Automation is designed for t.t.l., d.t.l. and m.o.s. logic, but it will also test individual integrated circuits including m.s.i. and l.s.i. devices. Basic capacity is for boards with up to 80 ways, but larger boards can be tested in two or more stages. Logical operation is checked by comparison with

a reference board. The tester is programmed by a pre-wired plug-in unit. Maximum test rate is 2MHz and most boards require only a few seconds testing time. Alternatively, the test sequence can be set to stop when a fault is detected so that its cause can be traced. Ryley Automation Ltd., 376 Ringwood Road, Poole, Dorset. WW316 for further details

### Printed circuit board

Nip Electronics supply NIPPIBOARD general purpose printed circuit boards for circuits using up to five transistors. The board available is shown in the photograph and requires drilling before use.

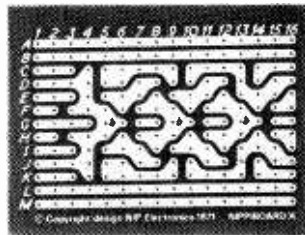

These boards come in fibre-glass and s.r.b.p. versions as single, double, triple (etc.) units. The one-off prices are 15p for the s.r.b.p. and 18p for the fibre-glass versions. Nip Electronics, P.O. Box 11, St. Albans, Herts. WW322 for further details

### Voltage controlled oscillator

The 471 signal source, from Brookdeal, is an oscillator providing sinewaves with distortion less than 0.1%, and square waves with a risetime of 30ns. With

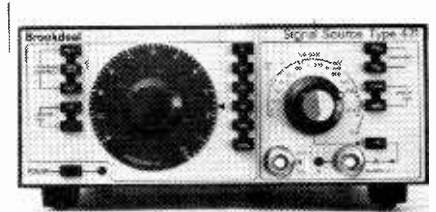

change of frequency waveform amplitude remains constant. The instrument incorporates a triangular waveform generator able to produce an unusually pure waveform. A network shapes the triangle into the required sinewave in a series of straight-line approximations. The high-order harmonics are removed by passing the waveform into an active RC filter, the tuning of which tracks the frequency of the triangular waveform generator.

#### Specification

frequency range 1mHz-1MHz (6 ranges)  
waveforms sine and square  
frequency control linear 10<sup>2</sup>:1  
range log 10<sup>4</sup>:1

Size is 218 × 87 × 285mm. Power supply 100-130V or 200-260V, 50-60Hz. Price is £229. Brookdeal Electronics Ltd., Market Street, Bracknell, Berks.

WW324 for further details

### I.C. heatsink

A twisted vane heatsink from Redpoint, type DIP 10/2, will mount the Plessey SL 403 series i.c. audio amplifiers with corresponding holes in the metal bridge

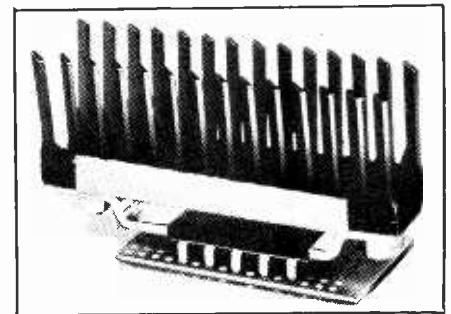

and when thus fitted is rated at 8.2°C/W. Height is 25mm. Price for 100 up is £0.71 with black anodized finish. Redpoint Ltd., Lynton Road, Cheney Manor, Swindon, Wilts.

WW 303 for further details

### Electronic organ attachment for piano

A piano keyboard can be partly converted to an organ console by the addition of two slim plastic units wired to a novel oscillator and sound reproducer. The system is called the PianoMate and is made by Dübreq Studios. Between them the units contain gravity operated switches which contact all the keys over four octaves of the piano's range. Like the piano the tuning is equally tempered, and there is a fine pitch adjustment which will raise or lower the whole system to bring it in line with a piano deviating from concert pitch. A wide range of

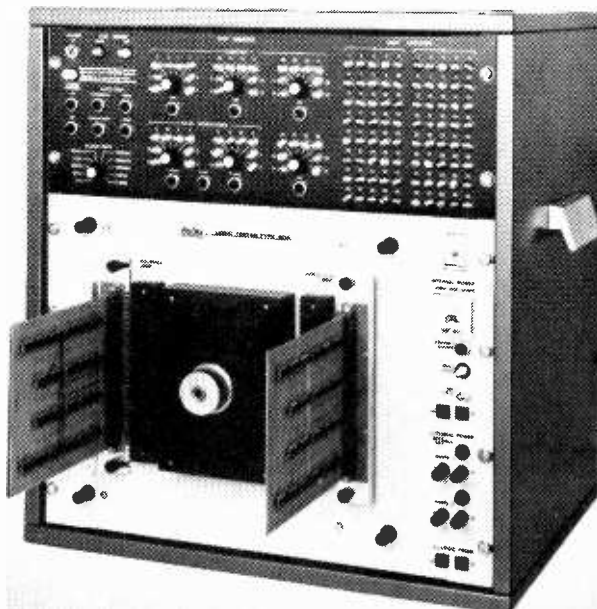



tone effects are possible including a two-speed vibrato. The piano can be played softly or loudly, the 'organ' volume level being set by a foot control. Price for equipment (as shown in the photograph) is £69. Dübrex Studios Ltd., 249/289 Cricklewood Broadway, London N.W.2.

**WW 325 for further details**

### Wide-range linear detector

Model 1008 a.c./d.c. converter from Pacific Measurements, of Palo Alto, Cal., exhibits a wide frequency range, wide dynamic range, high sensitivity and linearity, and rapid response. In the  $\times 1$  output multiplier step, signals from  $300\mu\text{V}$  to  $1\text{V}$  can be accommodated for a dynamic range of 70dB whilst additional steps of  $\times 10$ ,  $\times 100$  and  $\times 1000$  may be used to accommodate input signal levels up to 500V.

#### Specification

frequency range 5Hz to 5MHz  
dynamic range 70dB minimum ( $300\mu\text{V}$  to 1.0V) 5Hz to 1MHz  
60dB minimum (1.0mV to 1.0V) 1 to 5MHz

The input characteristic has been designed to be compatible with standard oscilloscope probes for low circuit loading. Aveley Electric Ltd., Arisdale Avenue, South Ockendon, Essex.

**WW327 for further details**

### Audio frequency test set

A test set capable of measuring audio sensitivity, power output, frequency response, hum and noise levels, cross-talk and total harmonic distortion, is available from Echometrix. The audio frequency generator made by Interecho System Ltd., of Rayleigh, Essex, operates at frequencies of 100Hz, 400Hz, 1kHz,

5kHz and 15kHz (other frequencies optional) and the output is adjustable from  $300\mu\text{V}$  to  $1\text{V}$ , being read off a separate output meter. The audio millivoltmeter measures 0 to  $1\text{V}$  in three steps; input impedance is  $1\text{M}\Omega$ , frequency range 25Hz to 100kHz within 1dB. The distortion factor meter measures 0-10% in two ranges, and the audio output meter measures  $0.5\mu\text{W}$  to  $20\text{W}$  with input impedance from 1.5 to  $600\Omega$ . Echometrix Ltd., 113/115 The Broadway, Leigh-on-Sea, Essex.

**WW328 for further details**

### Low-cost oscillator

The Farnell ESG1 oscillator is a low-cost instrument providing a source of sine- or square-waves from 10Hz to 1MHz with a useful output of up to 12V peak to peak.

#### Specification

frequency range 10Hz to 1MHz in five ranges  
scale accuracy to within  $\pm 2\%$  of scale reading  
harmonic distortion 10Hz-100kHz less than 0.5%

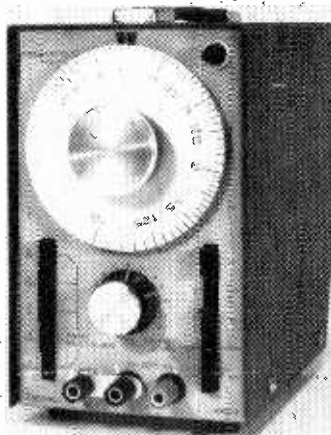

100kHz-1MHz less than 2% stability (short term 8 hrs) variation less than 0.2% amplitude stability  
10Hz-100kHz less than  $\pm 2\%$   
100kHz-1MHz less than  $\pm 5\%$   
output voltage adjustable 12mV to 12V pk-pk  
sync. output greater than 5V pk-pk  
Overall size is  $187 \times 109 \times 230\text{mm}$ .  
Weight 3.4kg (approx). Operation is from 105-120V or 200-240V, 50-400Hz. Price £34 (approx). Farnell Instruments Ltd., Sandbeck Way, Wetherby, Yorks, LS22 4DH.

**WW323 for further details**

### Microwave capacitors

G.E. Electronics (London) have announced a range of AVX Aerovox microwave ceramic capacitors having very high  $Q$  and low insertion loss. Featuring 'Ceralam' monolithic construction, the capacitor pellets (types HF-1 and HF-11) are rated up to 50W, with an insertion loss of less than 0.03dB at 10W. The units are

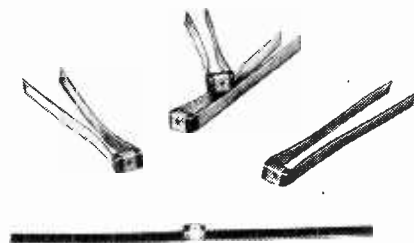

available in capacitances from 0.1 to 1000pF, working voltage ratings of 100, 200, 300 and 500V d.c. and with five capacitance tolerances, above 10pF, from  $\pm 1\%$  to  $+20\%$ . The v.s.w.r. rating is less than 1.05:1. G.E. Electronics (London) Ltd., Eardley House, 182/184 Campden Hill Road, Kensington, London W8 7AS.

**WW326 for further details**

### High-energy lithium battery

A small high-energy lithium battery type G2600-B has been developed by Honeywell for long-term storage applications. The battery is 1 inch in diameter and 1.4 inches long, and weighs 26.2g. Nominal voltage is 3.2V. Storage potential of more than ten years is made possible by isolating the electrolyte in a glass ampule to keep it from the lithium anodes. An external cap, provided with the cell, uses a pin to shatter the ampule and activate the battery. Then, depending on storage temperature, it can maintain most of its charge for many weeks. From  $-40$  to  $+75^\circ\text{F}$  the battery will last 500 hours at one milliamperere continuous current drain, 20 hours at 20mA, and 12 hours at 50mA. At over  $165^\circ\text{F}$ , with a current drain of 1mA, the battery will last 400 hours. Honeywell Ltd., Charles Square, Bracknell, Berks.

**WW330 for further details**

# Literature Received

For further information on any item include the appropriate WW number on the reader reply card

## ACTIVE DEVICES

A catalogue published by The M-O Valve Co. Ltd, Brook Green Works, London W.6, called 'Transmitting and Industrial Tubes', lists the characteristics of about 200 types. A comprehensive equivalents section is included . . . . . WW401

'Semiconductor Summary 1971/72' (6000/303E) gives details of transistors, rectifiers, thyristors, various sorts of diodes and integrated circuits manufactured by ITT Semiconductors, Footscray, Sidcup, Kent . . . . . WW402

'LSI Product Guide' gives data on a range of m.o.s. integrated circuits. Intel Corp., 3065 Bowers Ave., Santa Clara, California 95051, U.S.A. . . . WW403

Bulletin E2114/E2120 from International Rectifier (Great Britain) Ltd, Hurst Green, Oxted, Surrey, is devoted to 6 and 12A bulk avalanche rectifier diodes with p.i.v.s from 600 to 1200V . . . . WW404

A data sheet gives the performance of the f.e.t. operational amplifier LH0042 (input offset 5pA, offset voltage drift 10 $\mu$ V/°C, single 10k $\Omega$  pot. zero set without c.m.r.r. degradation, c.m.r.r. = 86dB). National Semiconductor (U.K.) Ltd, Larkfield Industrial Estate, Greenock, Scotland WW405

'Focus', a brochure from Jasmin Electronics, Station Rd, Quorn, Leicestershire LE12 8BP, gives details of the J7400 series of t.t.l. digital integrated circuits . . . . . WW406

The manufacturing division of Jermyn Industries, Vestry Estate, Sevenoaks, Kent, has produced a comprehensive catalogue of semiconductor hardware. It lists transistor and i.c. sockets, mounting pads, heat sinks etc. . . . . WW407

## PASSIVE COMPONENTS

Blore Barton Ltd, Reedham House, Burnham, Bucks, has produced a catalogue devoted entirely to potentiometers . . . . . WW408

The 'Blue Line' catalogue lists a variety of electronic components from, Bourns, International Rectifier, Keyswitch, Plessey, Texas Instruments and Union Carbide. Blue Line Electronic Components, Refuge House, River Front, Enfield, Middx. . . . . WW409

Lebury & Co. (Metals) Ltd, 76/78 North End, Croydon, CRO 1UJ, have a leaflet which describes a front panel terminal intended for use when very low contact resistance is important. The gold plated terminal has a stem resistance of 30 $\mu\Omega$  and thermal e.m.f. is only 0.2 $\mu$ V/°C . . . . . WW410

We have received a folder from E.M.I. Electronics and Industrial Operations, Hayes, Middx, containing the following literature:

R/M001a R71. 'Flexible printed wiring', discusses the properties of flexible printed wiring . . . . . WW411

'Microelectronics', covers facilities offered by E.M.I. for thin- and thick-film microcircuit production . . . . . WW412

Delay lines . . . . . WW413

Cambion Electronic Products Ltd, Castleton, Nr. Sheffield, Yorks S30 2WR, have produced a large catalogue which is written in English, German, French and Italian and employs only metric dimensions. The catalogue, called M747, lists and describes solder terminals, terminal boards, insulated terminals, coil forms, coils, r.f. chokes, capacitors, converters, i.c. accessories, thermoelectric devices, hardware and products for wire wrapping . . . . . WW414

'Modulo' is the name given to a range of low insertion force printed circuit edge connectors available with from 5 to 85 (single) or 10 to 170 (double) contacts. The range is described in the 'Modulo' catalogue from Pye Connectors Ltd, Hitchin St., Biggleswade, Beds. . . . . WW415

Highland Electronics, 33-41 Dallington St, London E.C.1, have introduced a new range of illuminated push-button and key switches which can have up to 84 contact springs (i.e. 28 changeovers) per switch. The range is described in a leaflet . . WW418

'Bulbs for signal fittings' is a leaflet published by A. F. Bulgin & Co. Ltd, Bye-pass Rd, Barking, Essex, which lists a variety of miniature lamps, in sizes from T.1 to B.C. suitable for use in Bulgin signal fittings . . . . . WW419

## APPLICATION NOTES

We have received two publications (in English) from the Danish Research Centre for Applied Electronics, Elektronikcentralen, Venlighedsvej 4, DK-2970 Hørsholm, Denmark. They are:

ECR-08E. 'Lubricants for electrical contacts'.

An investigation into the properties of 28 different lubricants. (This is a very thorough report) . . . . . Price D.kr. 30.00

ECR-22. 'Screening efficiency of coaxial cables at v.h.f.' A measuring method concerning electro-magnetic coupling into coaxial cables from near-by lines at v.h.f. Includes the theoretical background . . . . . Price D.kr. 30.00

Bulletin 1169 from Multicore Solders Ltd, Hemel Hempstead, Herts., gives an introduction to mass-soldering printed circuits . . . . . WW420

Two application notes are available from ITT Semiconductors, Footscray, Sidcup, Kent. They are:

'Transformerless stabilized power supply for monochrome TV' . . . . . WW421

'Optimizing transmission line impedances for maximum noise margin when driving t.t.l.' . . . . . WW422

## EQUIPMENT

If you send 15p postage to Lasky's Radio, 3-15 Cavell St, Tower Hamlets, London E1 2BN, you will receive a 44-page audio, communications and electronics catalogue and you will also be placed on the mailing list to receive future editions free.

A defluxer, microphones and headphones, a signal-operated switching unit, tape, a foot switch, a tape recorder test set and other items are included in the Audio Accessories catalogue from The Ferrograph Co. Ltd, The Hyde, Edgware Rd, Colindale, London N.W.9. . . . . WW424

Non-contacting transducer equipment for measuring such things as displacement, roundness, thickness and bore are described in a 12-page brochure from Wayne Kerr Co. Ltd, Tolworth Close, Tolworth, Surbiton, Surrey KT6 7ER . . . . . WW425

A leaflet may be obtained from Motion Electronics Ltd, Addestead Farm, Tonbridge Rd, East Peckham, Kent, which describes a range of television v.h.f., u.h.f. and v.h.f. plus u.h.f. sound tuners for connection to high quality sound systems.

The instrumentation catalogue from Heathkit describes a very wide range of electronic test equipment from a variety of moving-coil measuring instruments, power supplies, and signal generators to oscilloscopes, chart recorders, digital indicators

and spectrophotometers. All of the equipment can be obtained factory assembled but some items are also available in kit form. Heath (Gloucester) Ltd, Gloucester GL2 6EE . . . . . WW426

Coutant Electronics Ltd, Trafford Rd, Reading, RG1 8JR, have produced a short-form catalogue which covers complete power supply units, regulator cards and encapsulated thick-film regulators and over-voltage protection units . . . . . WW427

An integrated circuit tester and analyser for i.c.s with up to 16 leads is the subject of a leaflet from Seratan (Electronic Services) Ltd, Glebe Rd, Urmston, Manchester M31 1AL. The tester incorporates a switchable lead connection matrix, three programmable power supplies (0-20V in 10mV steps and 0 to 100mA in 1, 10 and 100 $\mu$ A steps); a pulse generator with variable rise and fall time, frequency and width; and a choice of moving-coil or digital readout . . . . . WW428

We have received the following literature from Telequipment, 313 Chase Rd, Southgate, London N14 6JJ:

DM64. Dual-trace storage oscilloscope . . . . . WW429

D65/6. Dual-trace oscilloscope . . . . . WW430

CT71. Transistor curve tracer . . . . . WW431

T.M.D. Ltd, 11 Redvers Rd, London N.22, have supplied us with the following literature which deals with Koss products:

'Choosing the sound of Koss that's best for you'.

Discusses the merits of dynamic and electrostatic headphones in simple terms and describes the Koss range . . . . . WW432

'Koss stereophones'. General sales leaflet . . . . . WW433

'Dealer News' . . . . . WW434

The Croydon Precision Instrument Co., Hampton Rd, Croydon CR9 2RU, have a leaflet available which covers a range of electronic measuring equipment manufactured in Germany by Norma . . . . . WW445

Leaflets are available from Amer Agencies, 36a Dryden Chambers, 119 Oxford St, London W.1 which describe a printing calculator and a small office computer manufactured in Bucharest by Electronom . . . . . WW446

'Cyclone III' is a 550W p.e.p. five-band (80, 40, 20, 15 and 10m) transceiver from Hallicrafters Co., 600 Hicks Rd, Rolling Meadows, Illinois 60008, U.S.A. A leaflet gives full details . . . . . WW447

Three frequency counters are the subject of literature from Stanley Laboratories Ltd, 26-30 John St, Luton, Beds. LU1 2JE . . . . . WW448

A leaflet describes the EMT180C electrical machines teaching laboratory produced by Feedback Instruments Ltd, Park Rd, Crowborough, Sussex . . . . . WW449

## GENERAL INFORMATION

The Engineering Information Department of the B.B.C., Broadcasting House, London W1A 1AA, have sent us the following information sheets:

4919(9). Map of main u.h.f. television transmitters 1030(5). List of m.f. and l.f. radio transmitters

A directory of B.C.S. approved laboratories can be obtained from the British Calibration Service, Ministry of Technology, Stuart House, 23/35 Soho Sq., London W.1 . . . . . WW450

'Profit from Facts' is a booklet published by the Government Statistical Service, Great George St, London SW1P 3AG, which illustrates how firms can make use of Government statistics . . . . WW451

'Towards Tomorrow's Communications' and 'Materials Evaluation Services' are two booklets which describe the facilities offered by Standard Telecommunication Laboratories Ltd, London Rd, Harlow, Essex . . . . . WW452

The Association of Franchised Distributors of Electronic Components (AFDEC), Bury Cottage, Wyddial, Buntingford, Herts., have published a booklet 'Guaranteed Component Distribution' which surveys the products, services and franchises of its members . . . . . WW453